



NEWSLETTER

VOLUME 5 NUMBER 3

JULY 1988

440 MHz FOX HUNT - ARE YOU INTERESTED?

For those ATCO members who enjoy the spirit of the chase, a hidden transmitter hunt in late summer or early autumn is under consideration. Let the ATCO Tuesday Night Net Control Operator know if you think such an event would provide an opportunity for a group gathering. To help you get ready, construction details for the necessary fox hunting gear are on page three.

INSIDE THIS ISSUE:

1988 ATCO Technical Symposium Report.....	Page 2
440 MHz Hidden Transmitter Finder.....	Page 3
1.2 GHz ATV Transmitter.....	Page 4
ATV News Items of Interest.....	Page 9
Helpful Hint.....	Page 10
Financial Statement.....	Page 11
Membership Roster Changes.....	Page 11

The ATCO Newsletter is the official publication of a group of television amateurs known as "AMATEUR TELEVISION IN CENTRAL OHIO" and is published in January, April, July, and October.

Membership in ATCO is open to any FCC licensed radio amateur who has an interest in amateur television.

Any reproduction of material printed in the ATCO Newsletter without the written consent of ATCO is prohibited.

ATCO MEMBERS TURN OUT FOR 1988 ATV TECHNICAL SYMPOSIUM

On Thursday evening 14 April, the 1988 ATCO Technical Symposium was held at the DeVry Technical Institute on Alum Creek Drive.

Twenty-seven ATVers were in attendance and enjoyed Bill Parker's enlightening discussion on the technical comparison of AM and FM fast scan ATV modulation. During his presentation, Bill showed many original graphic slides to illustrate his concepts.

At the start of the evening's program, members and guests were introduced. During the intermission, door prizes furnished by Bill, W8FRQ, and Bill, W8DMR, were awarded to lucky winners. Next, a 14 inch black and white TV monitor was presented by W8FRQ to Dick, W8RVH, the winner of the January Arithmetickler Contest. Then, W8DMR was given a computer print-out of a picture which W8FRQ had made of W8DMR "off the air some years ago." Members attending the Symposium expressed their appreciation for W8DMR's many contributions to amateur television and for his technical assistance to local ATVers by signing their names under the picture. A planned social hour at a nearby restaurant did not take place due to an apparent misunderstanding by its management.

Our thanks to the following people: those at DeVry who made it possible for us to use their excellent classroom facilities; Dave, KB2ARL, for his talk-in on 147.45 MHz; and W8DMR for making the arrangements for the meeting.

NEW ATCO MEMBER

Welcome to Ed, N8FFO, who joined ATCO in April.

SOLUTION TO APRIL ARITHMETICKLER

Did you figure out this one?

Here's the answer: If $A = B$, then $A - B = 0$.

Note - in line 4 of this problem printed in the April issue of the ATCO Newsletter you cannot divide by zero.

TV STATION BOASTS 1600 FT TOWER

WCOM-TV, channel 68 (794-800 MHz), located in Mansfield is now on the air and can be seen in the Central Ohio viewing area. The station operates with an authorized power of 2500 kW (2.5 megawatts!) visual and 250 kW aural. The antenna is 1600 feet above average terrain and 3000 feet above sea level.

440 MHz HIDDEN TRANSMITTER FINDER

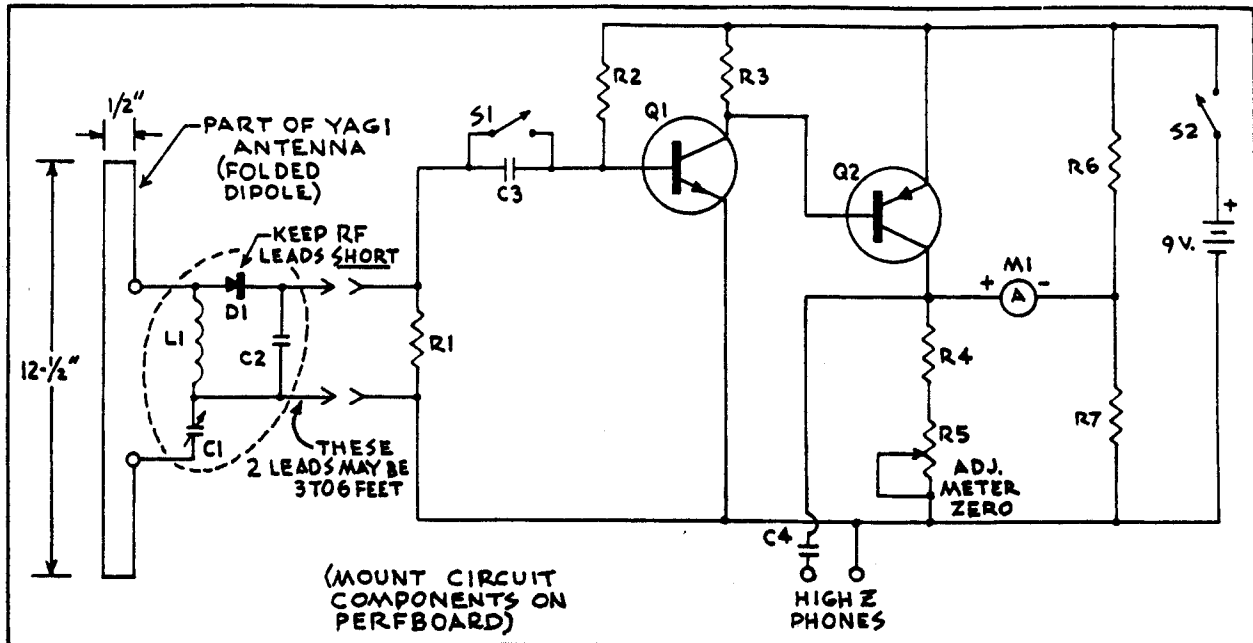

TWO TRANSISTOR DIRECT COUPLED AMPLIFIER CIRCUIT

The schematic diagram above details the circuitry for a hidden transmitter finder and a pickup folded dipole. A parts list and construction information for the antenna follow.

PARTS LIST

C1 - 3-12 pF trim cap.	Q2 - PNP 2N3906
C2 - .001 uF	R1 - 47 k ohms
C3 - .047 uF	R2 - 4.7 M ohms
C4 - 0.1 uF	R3 - 1 k ohms
D1 - 1N34A diode	R4 - 470 ohms
L1 - 8 turns #20 wire, 1/4" dia.	R5 - 10 k ohms pot.
M1 - 50-200 uA meter	R6, R7 - 4.7 k ohms
Q1 - NPN 2N3904	S1 - meter DC switch
	S2 - power switch

ANTENNA CONSTRUCTION DETAILS - The antenna is a 4 element Yagi with a wooden boom. Dimensions for the folded dipole are shown in the circuit diagram. The driven element, directors, and reflector are to be made from 1/8" diameter aluminum or copper wire. Director 1 (D1) is 12-1/4" long and Director 2 (D2) is 12-1/8". The Reflector (R) is 13-3/8" in length. All elements are spaced 5-3/8" apart. Elements are mounted on the boom in the following order: D2; D1; Driven Element; R.

OPERATION - (1) Listen for signal with S1 open. (2) When close to hidden transmitter, close S1 and watch meter for maximum reading. (Submitted by Bill, W8DMR.)

1.2 GHz ATV TRANSMITTER

This article describes a crystal controlled AM modulated 1.2 GHz ATV transmitter. To produce quality video on 1278 MHz, a 426 MHz transmitter acts as a driver for the 2C39 tripler (see Fig. 1).

Several drawings are included which give complete details for the construction and assembly of the tripler. Designs for the driver and power supply are not included since these are otherwise available or ready-made equipment may be obtained from commercial manufacturers.

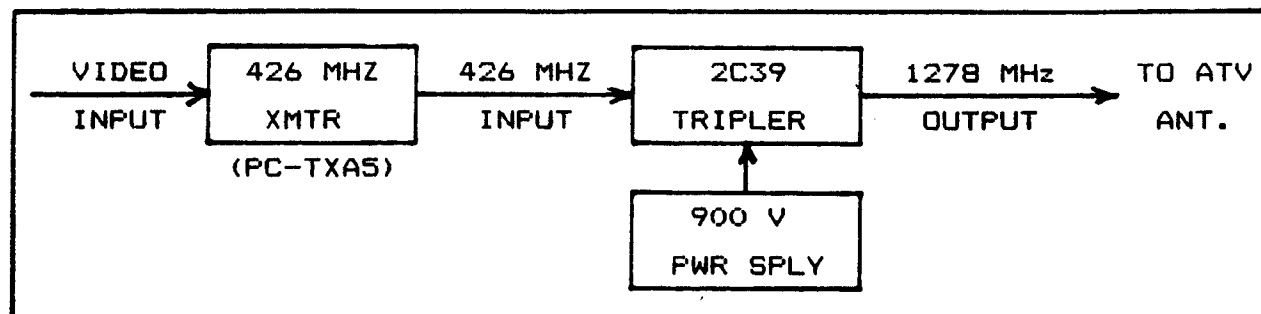

Fig. 1 - BLOCK DIAGRAM

ASSEMBLY PROCEDURES

The amplifier is a grounded grid tripler with strip line inductors (see Fig. 2 for schematic drawing). For the main part of the assembly, a 20 gauge aluminum 4" x 4" x 2" box with 4" square covers for the top and bottom is required - do not deviate from these dimensions.

No detail is shown for R7. This item is to be fabricated by using 46.5 inches of 24 gauge steel picture hanging wire insulated with Teflon, poly tubing, or heat shrink. Each end should be tinned with acid core solder and then washed with soap and water. Coil this wire on a length of 3/4" diameter wooden dowel and attach to the chassis or PC board with a wood screw.

The C6 adjuster (see Fig. 2) is made from a piston capacitor or any 32 thread screw with a threaded block fastened to the top panel of the plate box.

Fabricate all detail parts (all dimensions shown on drawings are in inches). Construct chassis and the control panel to your liking. Mount M1, all switches, and R1 (bias pot) on the panel. Mount blower and plate box on the chassis so that the output of the blower is directed toward one of the 1-1/8" diameter holes on the side of the box.

Next, mount grid capacitor, C9, to top of plate box (see Detail C9). The .010 Teflon is critical for good video. C9 must by-pass 1200 MHz but not video frequencies.

(continued on page 5)

1.2 GHz ATV TRANSMITTER

(continued from page 4)

A Teflon S0239 was used for the output, but "N" or "BNC" type connectors may be substituted.

Refer to Fig. 5 and install "F" fitting, C6 and adjuster, spacer (Detail "D"), grid box (see Figs. 4 and 7), and C8 to top cover.

Insert tube in L2 making sure the 1/64" hole is on the "F" fitting side. Then insert tube into C9 and tighten clamp screw. (Note that there are access holes to insert a screwdriver to tighten all clamp screws.)

Solder RFC3 from 1/64" hole in plate line to "F" fitting. Solder L3 to output fitting. Install 8-32" screw to clamp plate line L2 to spacer. Do not force tube into alignment. Adjust L3 to be level with the plate line and touching C8. Solder C8 to L3. Install solder lug under "F" fitting or grid box mounting screw. Solder C7 from lug to center pin of "F" fitting.

Solder copper tab to L1 (see Fig. 3). Install L1 on cathode of tube and tighten clamp. Install C3 and adjust so that stator lug can be soldered to L1. Solder R4 to C9 at the clamp ring and terminal of C5. Solder RFC1 to L1 and to grid box. Take filament connector and spread fingers created by saw cuts to make a snug fit in filament socket. Solder RFC2 to connector and terminal of C5.

Assemble grid box cover as shown in Fig. 3. Install cover and be certain "F" fitting makes contact with cathode and does not short filaments. Solder a stop nut on shaft of the C6 adjuster to prevent shorting with L2. Assembly may now be installed in box and wired.

TUNE UP AND OPERATION

If a Radio Shack voltmeter is used, it is wired to read 0 to 15 mA with S2 in the grid position and 0 to 150 mA in the plate position. Do not connect the high voltage yet. Connect an ac voltmeter to C5 and ground, close S1 and set voltage to 5.7 - 6.0 by adjusting R3. Check the bias voltage on C4 - it should adjust from -1.1 to -20.3 Vdc. Set bias to -10 V and apply rf from the 426 MHz driver. Adjust C3 for maximum grid current (<>5 mA). If a watt meter is not available, a 6.3 V @ 1.3 A pilot lamp may be connected to a suitable connector and terminated to the output connector and used as a power indicator. Turn drive off, and with S3 on apply the high voltage. Adjust the bias control so that the plate current is 1 to 5 mA.

Plate current should not exceed 100 mA maximum for this next test. If the plate current cannot be lowered to 90 to 100 mA

(continued on page 6)

1.2 GHz ATV TRANSMITTER

(continued from page 5)

with the bias control, reduce drive. Apply drive and observe plate mA and output. If plate mA current is satisfactory and some output is present, adjust C6 and C8 for maximum output (see Fig. 7 for tuning information). The amplifier will double to 852 MHz, and resonance should occur at minimum capacitance for both C6 and C8 at 1278 MHz. Now apply video modulation and tune for best picture. Plate tuning and drive affect picture quality the most.

PERFORMANCE DATA

Video modulated; plate volts 900; plate current 90 mA; grid current 2.5 mA; bias -10 V; input 81 watts; output is approximately 8 watts without modulation.
(Submitted by John, WABE0Y.)

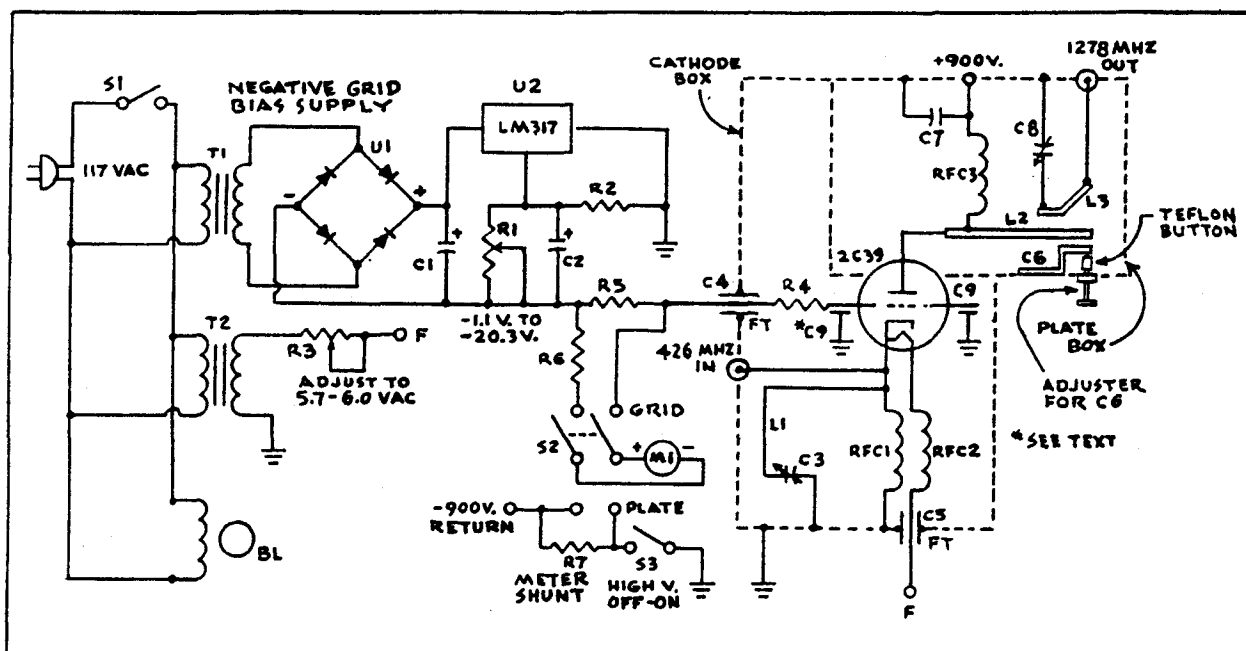

Fig. 2 - SCHEMATIC FOR 1.2 GHz ATV TRIPLER

- | | |
|---------------------------------------|---|
| C1 - 1000 uF, 35V (272-1032) | R3 - 1 ohm, w/slider, 10 W |
| C2 - 10 uF, 35V (272-1025) | R4 - 10 k ohms, 1 W |
| C3 - See detail | R5 - 10 ohms, 1/2 W (271-001) |
| C4, C5 - .001 uF, feed-thru | R6 - 68 ohms, 1/2 W (271-010) |
| C6 - See detail | R7 - See text |
| C7 - .001 uF, 3 k V, discs | RFC1, RFC2 - 10 turns #22, 1/8" dia., 5/8" long |
| C8 - 1-10 pF, piston | RFC3 - 4 turns #22, 1/8" dia., 5/8" long |
| C9 - See detail | S1 - SPST toggle sw. (275-602) |
| L1 - See detail | S2 - DPDT toggle sw. (275-666) |
| L2 - See detail | S3 - SPST toggle sw. (275-602) |
| L3 - See detail | T1 - 18 V, 2 A (273-1515) |
| BL - Blower to suit | T2 - 6.3 V, 1.3 A |
| M1 - Voltmeter, used as mA (270-1754) | U1 - Bridge rect (276-1180) |
| R1 - 5 k ohms, pot (271-1714) | U2 - LM317 VR (276-1778) |
| R2 - 100 ohms, 1/2 W (271-012) | |

NOTE: Numbers in parentheses are Radio Shack.

(continued on page 7)

1.2 GHz ATV TRANSMITTER

(continued from page 6)

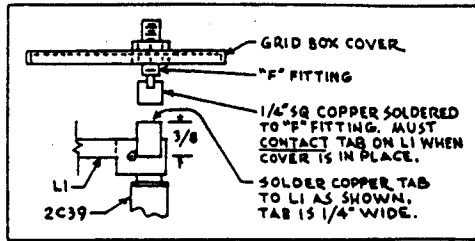

Fig. 3 - GRID BOX COVER ASSEMBLY

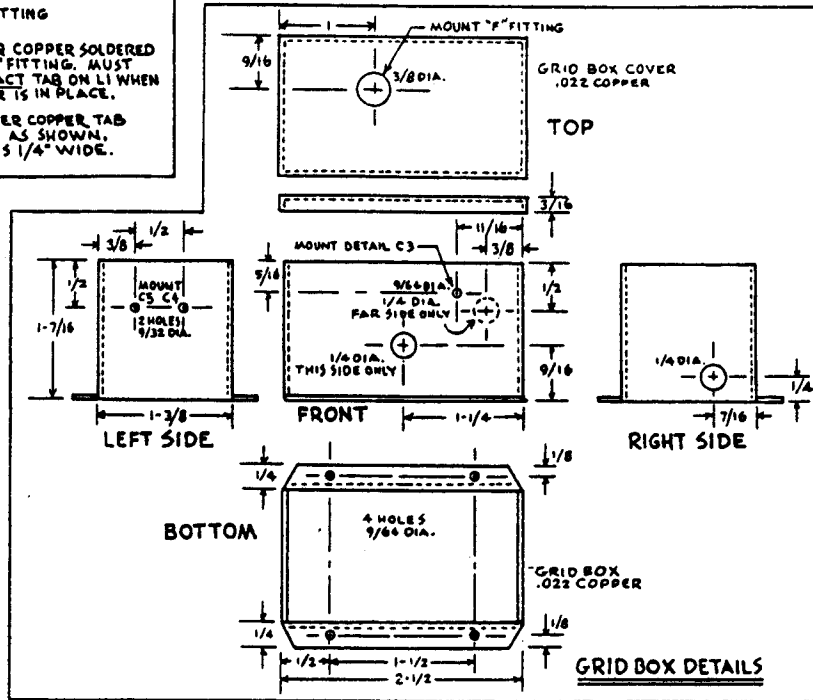
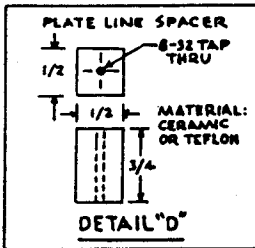
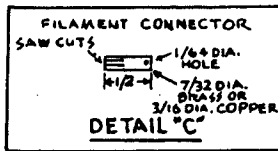
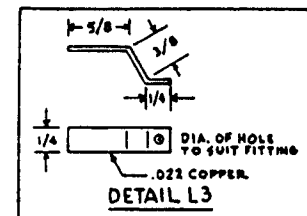
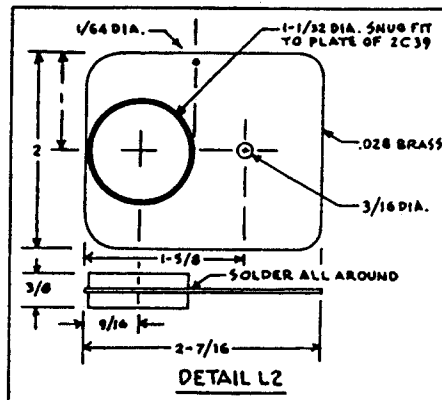
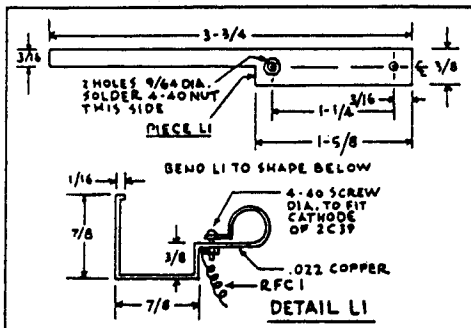
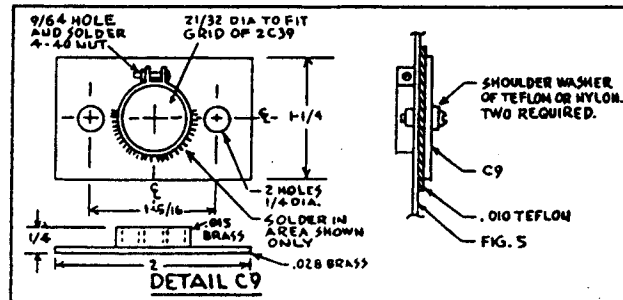
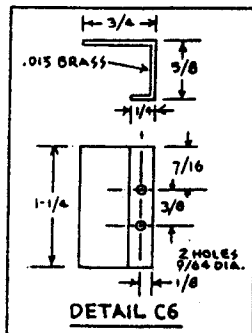
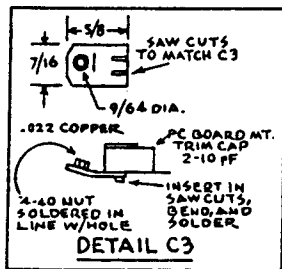

Fig. 4 - GRID BOX CONSTRUCTION DETAILS



(continued on page 8)

1.2 GHz ATV TRANSMITTER

(continued from page 7)

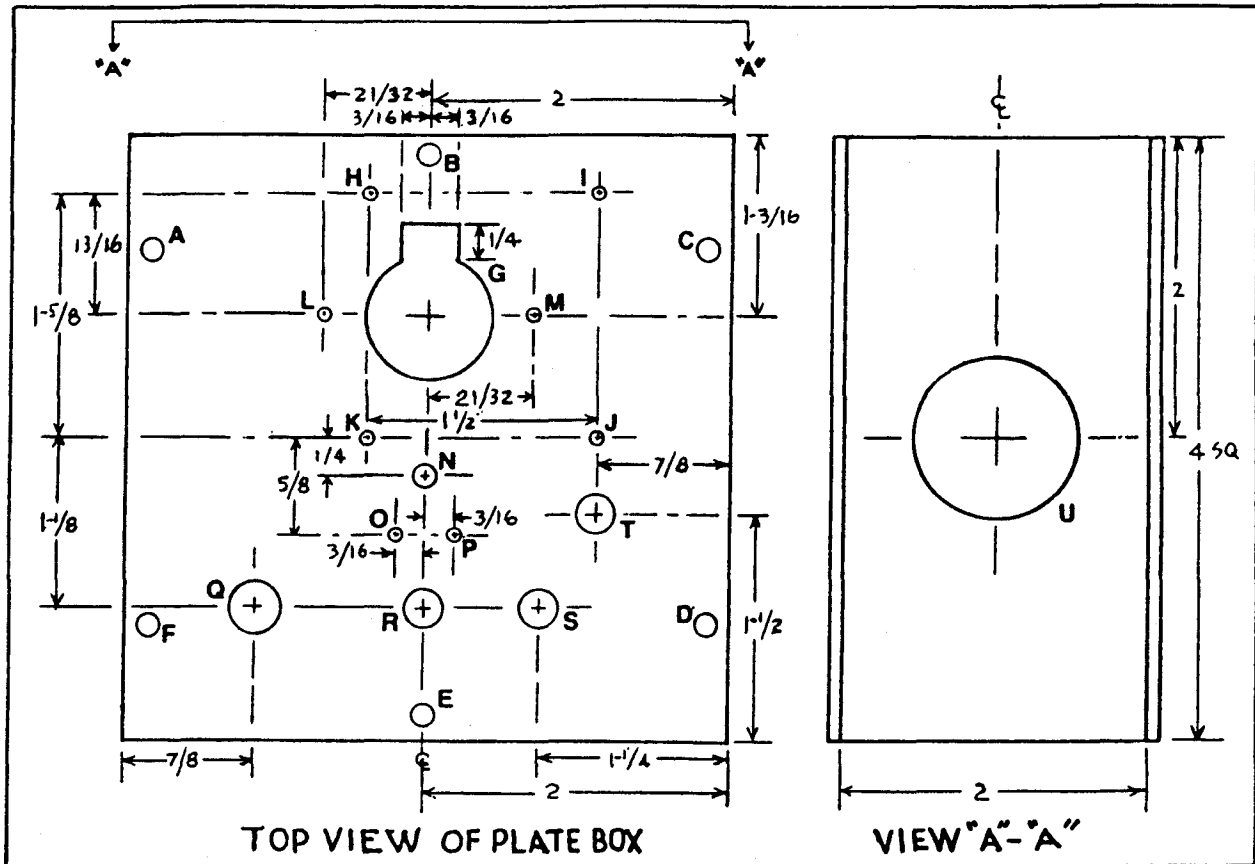

Fig. 5 - PLATE BOX CONSTRUCTION DETAILS

Diameters of holes:

- | | | | |
|--|---------------------------------|-----------|-----------|
| A thru F = size to match construction of box | H thru K = 9/64" | L = 5/32" | M = 5/32" |
| G = 7/8" | O = 9/64" | P = 9/64" | Q = 3/8" |
| N = 3/16" | S = size to suit output fitting | T = 9/32" | |
| R = 9/32" | | | |
| U = 1-1/8" | | | |

HOLE LETTERS	PURPOSE	LOCATION SIDE
H, I, J, K.....	To mount grid box.....	Shown
L, M.....	To mount Detail C9.....	Opposite
N.....	To mount Detail "D".....	Opposite
O, P.....	To mount Detail C6.....	Opposite
Q.....	To mount "F" fitting for H.V.....	Shown
R.....	To mount C6 adjuster.....	Opposite
S.....	To mount output fitting.....	Shown
T.....	To mount C8.....	Opposite

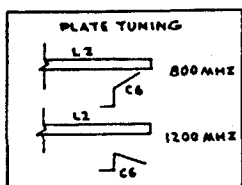

Fig. 6 - TUNING INFORMATION

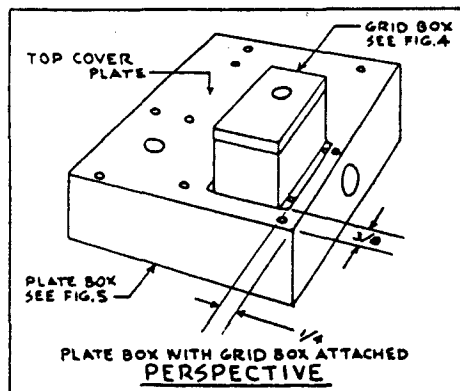

Fig. 7

ATV NEWS ITEMS OF INTEREST

By Bill, W8DMR

TWO ATCO MEMBERS SPEAK AT DAYTON HAMVENTION ATV FORUM - Bill, W88ELK, presented a wrap-up of his balloon launch activities as part of the forum conducted by Tom O'Hara, W6ORG. W88ELK's talk was well received with all the laughs in the right places.

W8DMR gave an unplanned program using the AM-FM ATV color slides prepared for the ATCO Technical Symposium. His discourse was interrupted by three young ladies displaying nightwear, but he welcomed the "brief" interlude.

W9PRD GREENSBURG (INDIANA) BALLOON LAUNCH - On Saturday 4 June at 9.58 a.m EDT, the W9PRD balloon was released and reached an altitude of close to 115,000 feet before its parachute descent at 12:27 p.m. The vertically polarized beacon signal on 144.34 MHz with ID was heard full quieting by many Central Ohio ATVers. Video was transmitted on 439.25 MHz with a horizontally polarized antenna. Several ATCO members taped the two video display generated pictures which alternately identified W9PRD and W88ELK. The beacon power was 500 milliwatts, and the video power averaged one watt peaking at two watts. W9NTP furnished the ATV transmitter and expert advice on the removal of some of the equipment "bugs." The frequencies of 3781 and 7156 kHz were used for coordination. All equipment carried on the balloon was recovered intact in a densely wooded area 86 miles southwest of the launch site.

W8BURI WORKS CENTERVILLE ON 1280 MHz - During mini-openings in recent months, Bill has twice been able to send video to Bruce, W8BUGV, located in Centerville, Ohio.

W8KQQ AND W8VSY TEST ON 910.25 MHz - Dale, W8KQQ, and Jack, W8VSY, at about 8:30 a.m. each day are attempting to send video pictures between Greenville and West Milton, Ohio. Dale is using his homebrew Yagi antenna (described in the April 1988 ATCO Newsletter) to see Jack's modulation bars on occasion.

W8EODY RECEIVES FIRST COMMERCIAL FM ATV XMTR FOR 1250 MHz - With a receiver and transmitter manufactured by Wyman Research, John is ready to view and transmit video. A 1250 MHz preamp is located on his 25 element loop Yagi antenna.

W8BURI'S NEW 1250 MHz DOWNCONVERTER - Bill's recent acquisition didn't work properly so he returned it to PC Electronics. It has now been sent back to him - the problem appears to have been corrected by replacement of the GaAs FET transistors.

3-D ATV - Recently, three-dimensional color ATV was transmitted by Bill, W8FRQ, and received in 3-D by Wilbur, K8AEH, and Dave, KB2ARL. This was accomplished by offsetting the RGB colors at the proper angle and viewing the video with 3-D glasses containing suitable filters.

HELPFUL HINT

An F-connector can be used on RG-8 coaxial cable by following these instructions:

1. Remove 1-1/2 inches of the vinyl jacket without nicking the braid. Fan the braid slightly and fold back over the cable.

2. Remove all but 1/4 inch of the exposed foam. Remove all but one strand of the center conductor and trim it to 1/2 inch.

3. Slip a 3/4 inch length of insulated sleeving over the braid. Push the F-connector on, compressing/trimming the foam.

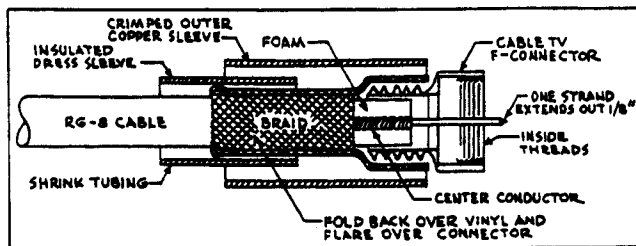

COMPLETED RG-8/F-CONNECTOR

4. Flare and roll the braid about 1/4 inch over the outer metal sleeve of the F-connector.

5. Crimp a split piece of copper tubing 3/4 inch long over the braid and connector sleeve. The single strand of the center conductor should extend out of the F-connector by at least 1/8 inch. (Submitted by Dave, WBAER.)

JULY ARITHMETICKLER

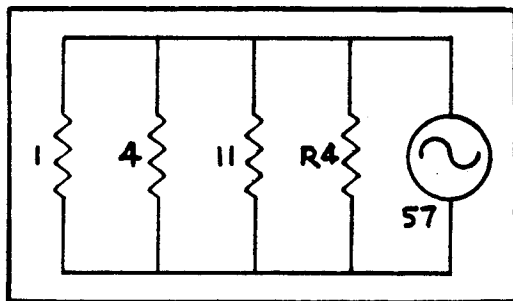

What is the logical value for R4?

A. 22 B. 16 C. 26 D. 4

(Submitted by Bill, W8FRQ.)

OUR CONTRIBUTORS

Thanks to the following for their contributions to the July 1988 issue of the ATCO Newsletter:

John, W8E0Y, for giving us complete construction details for building a 1.2 GHz ATV transmitter.

Bill, W8DMR, for his "440 MHz Hidden Transmitter Finder."

Dave, WBAER, who shows how an F-connector can be used on RG-8 coaxial cable.

Bill, W8FRQ, for his "Arithmetickler."

ATCO FINANCIAL STATEMENT

CASH BALANCE:
As of 31 March 1988.....\$436.09

RECEIPTS:
Dues.....\$ 40.00

EXPENDITURES:
Printing charges for April 1988 ATCO Newsletter.....\$ 39.88
Postage for April 1988 ATCO Newsletter..... 14.43
Misc. costs incidental to publication of newsletter.. 5.91

Total expenditures.....\$ 60.22

SUMMARY:
Cash Balance as of 31 March 1988.....\$436.09
Receipts..... 40.00
Expenditures.....- 60.22

Balance as of 30 June 1988.....\$415.87

25 CENT POSTAGE STAMP INVENTORY:
Stamps on hand as of 31 March 1988*..... 5
Stamps purchased 4 April 1988..... 10
Stamps used..... - 8

25 cent stamps on hand as of 30 June 1988..... 7

*Note: Item consists of five 22 cent and five 3 cent stamps.
The above financial report was prepared as of 30 June 1988 by
Warren G. Duemmel, KABGZQ, Acting ATCO Treasurer.

MEMBERSHIP ROSTER CHANGES

Please make the following changes to the list of ATCO members
appearing on page 12 of the April 1988 issue of your ATCO
Newsletter.

Change of address: KB2ARL, Dave DiGiuseppe, 5685-B Hibernia
Drive, Columbus 43232.

Change of call: WB8FWQ, Christopher Vojsak, is now WGBI.

Add new member: N8FFD, Edward Hauff, 2716 Columbus Avenue,
Columbus 43209.

Add renewals: WB8ELK, Bill Brown, 12536 T.R. 77, Findlay 45840;
WB8TMP, Dave Bourne, 2200 Dividend Drive, Columbus 43228;
KABZNY, Tom Taft, 386 Cherry Street, Groveport 43125.

THE ATCO TUESDAY NIGHT NET MEETS EVERY WEEK AT 8 EST AND 9 EDT

Editor: Warren, KABGZQ
Technical Editor: Bill, W8DMR

FIRST CLASS MAIL

ATCO NEWSLETTER
c/o Warren G. Duemmel
3488 Darbyshire Drive
Hilliard, Ohio 43026



ATCO FIELD DAY PARTICIPATION

WB8ELK, WB8URI, and KABZNY operated ATV at CARA's 1988 Field Day on 25 June from a site west of Hilliard. 439.25 MHz video contacts were made with W8DMR, WB8ELK mobile, W8E0Y, W8FRQ, W8BJEN, W8BTMP, W8RVH, and W8VWM via a 15 element homebrew Quagi antenna mounted on a 50 ft. tower.

W8E0Y's 1.2 GHz ATV TRANSMITTER

CONSTRUCTION DETAILS BEGIN ON PAGE 4
