

ATCO NEWSLETTER

VOLUME 28 NUMBER 2

April 2011

The ATCO newsletter is the official publication of a group of amateur television operators known as "AMATEUR TELEVISION IN CENTRAL OHIO Group Inc" and is published quarterly (January, April, July, and October)
Re-publication of ATCO newsletter material is encouraged as long as source credit is properly given.
Exception: "Reprinted by permission" material must have the original publisher's permission.

ATCO SPOTLIGHT TOPIC

Thanks to Greg Trook N0UJR for allowing us to share one of his cartoons. See also <http://incolor.inetnebr.com/n0ujr/>.

"Ya know Frank, I like the idea of having a radio along when we're deer hunting, but I'm not sure the overhead yagi array is a good idea at this time of year."



ACTIVITIES ... from my “workbench”



It's again time to put on my “thinking cap” to try to figure out what we did constructive since last time. It's truly difficult trying to concentrate with all this nice weather we're having right now (ABOUT TIME!!!!), but first, I hear the wife is asking if I plan to cut the grass today.....OK, that's done. Now back to work.

The first thing that comes to mind is our “pesky video IDer. As you may remember, I'm using a Sandisk picture frame generator to cycle through the various .jpg images on the flash thumb drive connected to it. It works great except for one thing, it must be manually restarted upon a power failure. This historically has not been a problem since a power loss incident occurs once a year or less. However, during the winter a large scale electrical update was made to the facility where the repeater is located. I initially thought we found a workaround by simulating a manual start-play sequence in a PIC processor installed in the Sandisk unit. That proved harder than we thought and was only marginal restarting it after a power interruption. So, my last attempt is to “do it right” by installing a battery backup/charger function in the controller supplying 5v power to the Sandisk unit. Now we have about 1 hour of backup time after loosing AC power. I think that's enough! So far, there are no problems.

Next, I changed the 1268MHz power amp for the digital output. I used a linear 28V LDMOS transistor the same as used in the analog 1258MHz amp with results nothing short of fantastic! We were using a Down East Microwave “linear” amplifier that gave an output of about 10 watts. With it came a sideband spectral regrowth that was only 20 dB down from the main carrier. This new amplifier outputs about 20 watts with sidebands down over 40 dB! That's almost better than commercial broadcast. In fact, I could adjust things to get a little higher signal to noise ratio with a sacrifice of somewhat less output power. I decided it's good the way it is with the 40dB SN and 20 watts output. I DO notice the difference at my QTH with less pixilation. WB8LGA also reports a stronger signal at his QTH more than 40 miles from the repeater.

Work is ongoing to clean up the repeater cable mess that existed some time ago. As I've reported before, I'm bringing all audio and video cables out the front of the respective modules which cleaned up most of it. There are still some improvements to be made but in due time. When WB8LGA finishes the new controller, I'll work on it some more. Work is in progress on that one. Charles reports he has written over 5000 lines of code and is now about 85% complete. The new system will give us much better control of individual signals not existing now. In addition, if we get internet access, all changes will be possible via internet. I'll have more on that one next time.

Here's a topic that was brought to my attention. It is suggested that I not publish member Email addresses in the Newsletter. The reason is that the ATCO Newsletter is passed around from group to group and eventually gets put on other web pages including the Email addresses. Malicious web surfers then zero in on these Email addresses to send unwanted spam to ATCO members. Kevin, W8KHW, requested that I remove his “address”. I blindly honored his request and removed his mailing address and leaving the Email address as is. Sorry, Kevin. So, this issue doesn't include Email addresses. If you feel it is important we list Email addresses, I can put them on our secure home page accessed only by members. Let me know your thoughts.

That's about all for now. However, don't forget our Spring Event on Sunday, May first in the ABB cafeteria, the same as last year. To allow for attendance at the Athens Hamfest the same day, we'll start at 1PM instead of noon so people can get back from Athens if they choose to attend both.

...73,
WA8RMC



SPECTRUM MANAGEMENT BILL THREATENS HAM FREQUENCIES

On February 10, Representative Peter King (R-NY-3), Chairman of the House Homeland Security Committee, introduced [HR 607, the Broadband for First Responders Act of 2011](#). The bill has been referred to the House Energy and Commerce Committee, which handles telecommunications legislation. HR 607 addresses certain spectrum management issues, including the creation and maintenance of a nationwide Public Safety broadband network. As part of that network, the bill provides for the allocation of the so-called “D-Block” of spectrum in the 700 MHz range for Public Safety use.

The D-Block consists of two, 5-megahertz-wide segments of spectrum (758-763 and 788-793 MHz) that became available when the FCC ended analog television broadcasts in June 2009 and reallocated the 698-806 MHz band for Public Safety and commercial broadband. It was anticipated that the D-Block would be auctioned for commercial use. There are several bills in Congress providing for the allocation of the D-Block for Public Safety use, and HR 607 is one of those. But HR 607 uniquely provides for the reallocation of other spectrum for auction to commercial users, in order to offset the loss of revenue that would occur as the result of the allocation of the D-Block to Public Safety instead of commercial auction. HR 607 lists the paired bands of 420-440 MHz and 450-470 MHz among the bands to be reallocated for commercial auction within 10 years of its passage.

“Of serious concern to the ARRL is the inclusion of the 420-440 MHz amateur allocation in the list of frequencies to be cleared for auction,” said ARRL Regulatory Information Manager Dan Henderson, N1ND. “The ARRL and the Amateur Radio community certainly support the work of public safety agencies and understand their desire for an interoperable network; however, the inclusion of most of the amateur 70 cm spectrum as one of the replacement bands is illogical and unacceptable. The 420-440 MHz band is not Public Safety spectrum and should never have been included in any spectrum swap of Public Safety allocations.”

Saying that the ARRL Washington team has already begun meeting with key Congressional staff on Capitol Hill, Henderson noted that Amateur Radio already shares the 70 cm band on a secondary basis with the governmental radiolocation services, such as the PAVE PAWS radar systems: “The 70 cm band is a critical and irreplaceable resource for Amateur Radio public service and emergency communications. The specification of the 420-440 MHz band in this legislation is ill-conceived. To be sure, the ARRL will vigorously oppose this legislation in its present form. It is, as evidenced by other legislation, completely unnecessary to the creation of a nationwide Public Safety broadband network or the use by Public Safety of the D-Block for that purpose. The role of the Amateur Service as a partner to Public Safety in the provision of public service and emergency communications necessitates the retention of full access to the entire 420-440 MHz band.”

HR 607 is presently cosponsored by the Homeland Security Committee’s Ranking Member, Representative Bennie Thompson (D-MS-2) as well as Representatives Shelley Berkley (D-NV-1), Yvette Clarke (D-NY-11), Billy Long (R-MO-7), Candice S. Miller (R-MI-10), Laura Richardson (D-CA-37), Mike Rogers (R-AL-3), and Michael Grimm (R-NY-13).

“As we continue to track the progress of HR 607, I urge ARRL members to watch for further information about the bill on the ARRL website,” Henderson said. “When that additional information is released, it will include a request to contact your representative and express opposition to HR 607, as long as it includes a provision to auction off any Amateur Radio spectrum for commercial use. ARRL members may also sign up for the *ARRL Legislative Update Newsletter* and automatically receive information as it becomes available. Sign up by logging onto the ARRL website and select the ‘Edit Your Profile’ link located at the top of each page. Once on that page, select the ‘Edit Email Subscriptions’ tab and click on the box for *ARRL Legislative Update*.” The *ARRL Legislative Update* is prepared on an “as needed” basis to those who have opted-in to receive it. A new edition addressing HR 607 will be forthcoming soon.

ARRL is asking its members to contact their US representatives in opposition to the sections of [HR 607](#) that could affect the Amateur Radio Service allocation at 420-440 MHz. HR 607, the Broadband for First Responders Act of 2011, would address certain spectrum management issues, including the creation and maintenance of a nationwide Public Safety broadband network. It was [introduced](#) into the US House of Representatives February 10.

ARRL Regulatory Information Manager Dan Henderson, N1ND, clarified that the League opposes HR 607 *in its present form*. “We do not oppose the concept of dedicated spectrum for the development of a Public Safety infrastructure and wireless network. We object to the bill because of the inclusion of 420-440 MHz as part of the spectrum to be swapped and auctioned to commercial users.”

You can find a sample letter, “how to find your Representative” and the contact information for ARRL’s legislative consultant, Chwat & Co, at <http://www.arrl.org/sample-letters>.

A LITTLE HUMOR (very little)

Have you heard about the engineer who got his finger stuck in the e-prom burner? He inadvertently programmed himself. He didn't notice any difference until he got to the grocery store and started shifting registers.

DAYTON HAMVENTION ATV FORUM DETAILS

The ATV forum at Dayton promises to be very interesting and informative this year. It will be held on Saturday May 21 at 3:30-5:00PM in room 2 in Hara Arena. It's the last forum of the day on Saturday so it will be convenient to attend and, if for no other reason, rest your feet before heading home. Please join us if you can. The presenter list and times follow.

TIME	SPEAKER	CALL	PRESENTATION TOPIC
1530-1539	Art Towslee	WA8RMC	Introduction.
1540-1550	Gordon West	WB6NOA	ATV net THEME ideas that work!
1551-1601	Mike Collis	WA6SVT/Bill Brown WB8ELK	ATVQ Magazine overview.
1602-1622	Lou McFadin	W5DID	DATV Space Station project and Oscar satellite activities.
1623-1633	Ken Konechy	W6HHC(*)	DATV Basics
1634-1644	Mike Collis	WA6SVT	ATV repeater linking in So. California.
1645-1700	Chris Oesterling	N8UDK	Boy Scout ATV rocket launch.

*Note: Ken will not be at Hamvention. He'll present via recorded DVD.

The presenter biographies are as follows:

Art Towslee WA8RMC

I have been involved with ATV since 1965 and am recently retired from my engineering job of 44 years. In the years since 1965 I've been involved in almost all aspects of ATV in the UHF/microwave bands including digital ATV. I am currently the president of the ATCO ATV group in central Ohio and the editor/publisher of the ATCO Newsletter. I have been the Hamvention ATV forum moderator for 4 years.

Gordon West WB6NOA

Gordon is a nationally known ham licensed for more than 40 years holding an Amateur Extra class license. Gordon teaches evening Ham Radio classes and weekend licensing seminars nationwide for both entering and upgrading Hams. He has served on the faculty of Coastline College and Orange Coast College and contributes regularly to ham radio, marine and general aviation magazines. He is a fellow of the Radio Club of America and a life member of the ARRL.

Mike Collis WA6SVT

Mike has been licensed since 1972. By 1979 he built an ATV repeater for the Los Angeles area and by the 1980s worked with other ATVerS to build and link more. His background is in Broadcast TV and currently is an engineer for CBS TV in LA.

Bill Brown WB8ELK

Bill has been involved with high altitude ballooning with and without ATV cameras for many years. He's the designer of the famous Elktronics TV identifier PCB used by almost all ATV repeaters for an on screen ID.

Lou McFadin W5DID

Lou is a (semi) retired NASA engineer presently involved with Ham Radio on the Space Shuttle and International Space Station. He worked on the first Ham Radio equipment flown on manned spacecraft STS-9 and then the flight which carried the first SSTV to orbit on STS-51F and continuing SAREX flights. Lou was Lab Manager for the P3D integration in Orlando from 1995 until launch. He continues as the U.S. Hardware Manager for the ARISS space programs including Suitsat and ARISSat. He is also the head of the Project Selection and Use committee which approves new projects for ISS Ham equipment. He is on the AMSAT BOD and continues his devotion to Amateur Radio in space.

Chris Oesterling N8UDK

Chris has been a licensed HAM for almost 20 years. He owns and operates an electronics manufacturing business that offers a dozen HAM related products including ATV controllers and video id boards. Over the years Chris has built many ATV projects including rockets, kites, blimps, high altitude balloons, RC cars, RC planes, and an ATV repeater located in Michigan. He holds over 90 issued and pending patents in various technologies.

DVB-S OR DVB-S2 FORMAT PRIMER

Here's an excellent technical article by Ken W6HHC that discusses the pros and cons of DVB-S vs. DVB-S2 digital TV. It is reprinted from the "OCARC Newsletter". It's more technical than we're used to so use it as reference material. The main point is that the differences show DVB-S2 better than DVB-S. However, ATV users will probably use DVB-S for the foreseeable future because of costs involved creating and receiving a DVB-S2 signal. (The ATCO digital signal presently is DVB-S).
...WA8RMC

TechTalk 92 DATV – Looking at DVB-S2 Modulation by Ken Konechy W6HHC Orange County Amateur Radio Club – W6ZE

Most of the earlier OCARC TechTalk articles about Digital-ATV have provided details about how DVB-S modulation works. DVB-S is currently the most popular modulation standard being used by hams for DATV. This month I will look at some of the technical details of DVB-S2 modulation technology.

While the majority of DATV hams use DVB-S modulation and some hams use DVB-T modulation (see TechTalk86), I have had some conversations with hams who propose that ham radio should move on to DVB-S2 modulation for Digital-ATV. I am a big advocate of understanding all the competing DATV technologies and protocols, since each technology has its own set of strengths and weaknesses (aka: PROs and CONs). So let us see, if DVB-S2 can improve ham radio Digital-ATV?

Commercial World of Television

The Digital Video Broadcasting organization (DVB) approved DVB-S2 to be the modulation technology for commercial High Definition TV (HDTV) broadcast satellite transmissions (uplinks and downlinks). The DVB organization succeeded in getting DVB-S2 approved as a ETSI standard in March 2005. The DVB organization states that "DVB-S2 will not replace DVB-S in the short or even the medium term, but makes possible the delivery of services that could never have been delivered using DVB-S".

Some of the commercial TV design goals for DVB-S2 are:

- Quasi-Error-Free operation at about 0.7dB to 1 dB from the Shannon limit
- Optimized for multi-stream HDTV
- Interactive Services (IS) Interactive data services including Internet access
- Digital TV Contribution and Satellite News Gathering (DTVC/DSNG)
- Data content distribution/trunking and other professional applications (PS)

I find it interesting to note that other than the first bullet above, none of the services and features in the other bullets are not of much interest to hams.

Typical Transmitter Block Diagram

DATV pioneer and enthusiast Stefan Reimann DG8FAC of SR-Systems in Germany has shown that DVB-S2 digital technology is possible for hams (see the SR-Sys model 2TS-MidiMOD2). **Fig 1** is a block diagram of a basic DVB-S2 ham station for DATV. The analog camera and video is compressed by a MPEG-2 encoder board. The TransportStream (TS) digital data is fed to the DVB-S2 exciter board that does a lot of complicated data processing and then converts the digital data directly into modulated RF at a desired frequency. The small RF output signal of the exciter board is typically amplified by two stages of very linear RF amplifiers.

Video Data-Rate and Compression

For DATV, the analog camera output is first digitized by the MPEG-2 Encoder board shown in **Fig 1**, and then compressed by the MPEG-2 algorithm. The reason the compressed video data rate varies in **Table 1** is that the small value means little motion in the video scene and the larger value means a lot of motion.

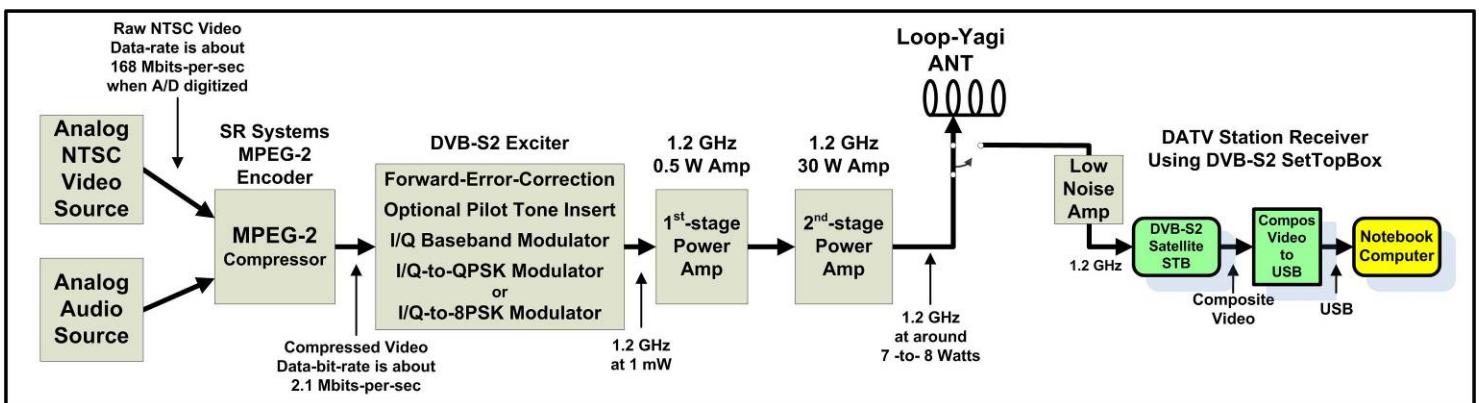

Figure 1 – Block Diagram of Basic DVB-S2 Station for DATV

Table 1 – Camera Video Data Streams and MPEG-2 Data Streams

Video Data Stream	Data-Rate	Notes
Analog NTSC camera	168 Mbits/sec	A/D digitized, uncompressed
NTSC MPEG-2	2-3 Mbits/sec	compressed
NTSC H.264/MPEG-4	~1.5 Mbits/sec	compressed
VHS MPEG-2	1-2 Mbits/sec	compressed
Analog PAL camera	216 Mbits/sec	A/D digitized, uncompressed
PAL MPEG-2	2.5-6 Mbits/sec	compressed
HDTV camera	1-1.5 Gbits/sec	uncompressed
HDTV MPEG-2	15-60 Mbits/sec	compressed
HDTV H.264/MPEG-4	12-20 Mbits/sec	compressed

Notice in **Table 1** that the digitized NTSC camera video stream data-bit-rate is 168 Mbits/sec before compression, and MPEG-2 will reduce this to a Net-Bit-Data-Rate between 1 and 3 Mbps, which is quite a reduction in the data rate,

The newer video CODEC, H.264, can be also used with DVB-S2. This CODEC is sometime called H.264, sometimes called MPEG-4-Part-10, and sometimes called Advanced Video Coding (AVC). But, all of these terms mean the same standard, technically. H.264/MPEG-4 can reduce the bit-rate by a factor of 50% over MPEG-2. However, the MPEG-4 encoding adds considerably to the latency of the transmitted signal, compared to MPEG-2.

FEC Inflation of Payload Data Stream Data-Rate

Forward Error Correction (FEC) is a technology that not only can detect errors on the received signal, but adds enough redundancy of the data so that it can correct several wrong bits. But, there is a trade-off when choosing the amount of redundancy. Since redundancy inflates the data-rate of the output stream, the trade-off is between more redundancy or keeping the inflated data-rate smaller. As we will see a little later in this article, the larger the inflated output data-rate, the higher the required RF bandwidth. So at some point the FEC algorithm will not have enough redundancy to correct too many errors, and the DATV receiver screen will go blank or freeze.

The FEC algorithms used in the DVB-S2 protocol are different that those used in the older DVB-S and DVB-T protocols. The DVB-S commercial television standard uses a first FEC algorithm called the inner-Punctured-Convolutional-Code encoding specification and then decoded by Viterbi. The second FEC algorithm is called Reed-Solomon. Combining the Convolutional encoding with Viterbi decoding is an FEC technique that is well suited to a channel in which the transmitted signal has been corrupted by Gaussian noise.

The Viterbi FEC algorithm can be configured for different levels of error correction. Theses different Viterbi configuration redundancy settings are usually called: 1/2, 2/3, 3/4, 5/6 and 7/8. The first number (“1” in the case of configuration 1/2) is the number of input bits. The second number (“2” in the case of configuration 1/2)

is the number which the transmitted signal has been corrupted by Gaussian noise.

The DVB-S2 FEC specification originated with the desire for improved efficiency. In DVB-S2, the DVB-S inner convolutional coding has been replaced with Low Density Parity Check (LDPC) coding and the DVB-S Reed-Solomon encoding is replaced with the Bose-Chaudhuri-Hocquenghem (BCH) algorithm for outer encoding.

The inner LDPC FEC algorithm can be configured for different levels of error correction. These different redundancy settings are usually called: 1/2, 3/5, 2/3, 3/4, 5/6, 8/9 and 9/10. (See **Table 2**) Where the first number (“1” in the case of configuration 1/2) is the number of input bits. The second number (“2” in the case of configuration 1/2) is the number of output bits from this FEC algorithm. In the case of “1/2”, the data “inflation rate” is 100%

The second algorithm that is used is the BCH FEC algorithm produces a variable length overhead. It adds an overhead of typically 192 bits to a long data body frame for the FECFRAME length of 64,000 bits. Its data stream “inflation rate” is very small, typically around 0.5% or less depending on the FEC Rate (see **Table 3** for exact values).

Table 2 – FEC rates for DVB-S2 Broadcasts

FEC	QPSK	8PSK	16APSK	32APSK
1/4	Optional	No	No	No
1/3	Optional	No	No	No
2/5	Optional	No	No	No
1/2	Yes	No	No	No
3/5	Yes	Yes	No	No
2/3	Yes	Yes	Optional	No
3/4	Yes	Yes	Optional	Optional
4/5	Yes	No	Optional	Optional
5/6	Yes	Yes	Optional	Optional
8/9	Yes	Yes	Optional	Optional
9/10	Yes	Yes	Optional	Optional

Table 3 – Value of BCH “inflation” for 64,800-bit Frame

FEC Rate	Frame lengths	CR _{BCH}
1/4	16,008 / 16,008 + 192	0.98815
1/3	21,408 / 21,408 + 192	0.99111
2/5	25,728 / 25,728 + 192	0.99256
1/2	32,208 / 32,208 + 192	0.99407
3/5	38,688 / 38,688 + 192	0.99506
2/3	43,040 / 43,040 + 160	0.99630
3/4	48,408 / 48,408 + 192	0.99810
4/5	51,648 / 51,648 + 192	0.99630
5/6	53,840 / 53,840 + 160	0.99704
8/9	57,472 / 57,472 + 128	0.99778
9/10	58,192 / 58,192 + 128	0.99780

Digital Modulation Symbols and Symbol-Rates

Digital modulation technologies like BPSK (an example is PSK-31), QPSK (Quad Phase Shift Keying), 8PSK and 32APSK (Amplitude and Phase Shift Modulation with 32 “constellation points”) have the ability to put more information into a more narrow frequency spectrum than analog modulation. The complexity of the digital modulation scheme, allows us to pack more “data bits” into each SYMBOL. **Table 4** lists out how many data bits can be packed into a symbol for several well known digital modulation technologies.

Table 4 – Symbol Bit-Packing for Various Digital Modulation Technologies

Modulation Scheme	Data Bits per Symbol (Me)
BPSK	1
GMSK	1
QPSK	2
8PSK	3
8-VSB	3
16APSK	4
QAM-16	4
32APSK	5
QAM-64	6
QAM-256	8

The higher-order modulations schemes, like 16APSK and 32APSK, can “pack” more bits into the symbol rate than QPSK. But, the complexities for 16APSK and 32APSK modulation make them more susceptible to noise and interference than QPSK. The DVB-S2 protocol provides for QPSK, 8PSK, 32APSK, and 32APSK (marked in **BLUE** in **Table 4**. The drawings in **Fig 2**, **Fig 3**, **Fig 4**, and **Fig 5** are intended to give an appreciation of the increasing complexities for these modulation schemes.

Notice in **Fig 4** and **Fig 5** that not only is the angle from the origin to the state important, but the amplitude from the origin is critical, also. Think of APSK as a modulation that is

similar to QAM modulation...but providing a circular constellation.

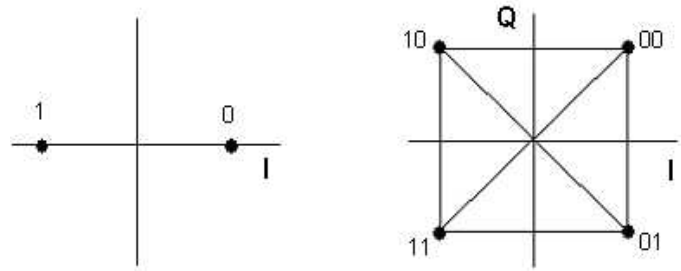

Figure 2 – The modulation constellations of BPSK (on the left) with two states and by QPSK with four states.

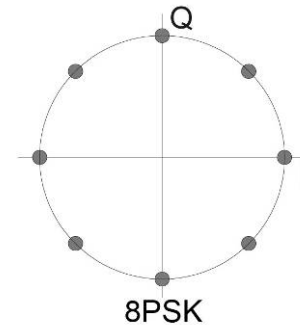

Figure 3 – The constellation for 8PSK modulation contains 8 states. Each state defines three bits of data.

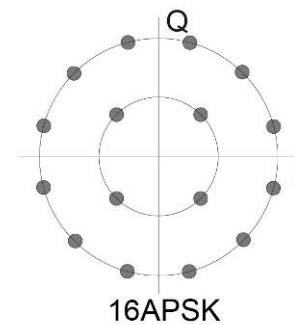

Figure 4 – The constellation for 16APSK modulation contains 16 states. Each state defines four bits of data.

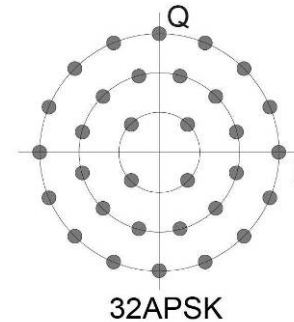

Figure 5 – The constellation for 32APSK modulation contains 32 states. Each state defines five bits of data.

Hans Hass DC8UE in Hamburg has conducted DATV testing to compare DVB-S2 to DVB-S. When testing with DVB-S (QPSK with FEC equal 1/2) he needs the signal to be 5.5 dB above the noise (C/N). With DVB-S2 QPSK (FEC = 1/2) he needed C/N = 2.2 and with 8PSK (FEC = 3/5) he needed C/N = 6.5. Clearly the more complicated 8PSK modulation is more susceptible to noise.

For commercial DVB-S2 satellite broadcasting, only the QPSK and 8PSK modulations are currently being used. Stefan DG8FAC of SR-Systems explains that commercially, “16APSK and 32APSK modulations are only for Ground Links [and for portable Uplinks] at the moment”. I do not know of any ham DATV installations that are currently using 16APSK or 32APSK modulation.

DVB-S2 Bandwidth

Table 4 shows for example that 8PSK modulation will pack three data bits into each symbol being modulated. If we know the final output data-bit-rate (I will call this inflated data rate the “Gross Data-Bit-Rate”) we need for the television signal, then the “symbol-rate” we need is exactly one-third of that gross data-bit-rate. That is: each symbol will produce three bits of data.

For example:

$$\text{Gross Data-Bit-Rate} = 4.5 \text{ Mbits/sec}$$

$$\text{Symbol-Rate Needed} = 1.5 \text{ Msymbols/sec}$$

The formula to calculate the Symbol-Rate setting that is needed for a DVB-S2 transmitter is:

$$\text{Symbol-Rate Needed} = \text{NDBR} / (\text{Me} \times \text{CR}_{\text{LDPC}} \times \text{CR}_{\text{BCH}})$$

Where:

- NDBR** = Net Data Bit Rate (aka the information rate)
Same as MPEG-2 output data rate in Fig 1
- Me** = Modulation Efficiency (3 for 8PSK in Table 4)
- CR_{LDPC}** = Correction Rate setting for LDPC (1/2, 3/4, etc)
- CR_{BCH}** = Correction Rate value for BCH found in Table 3

I will now calculate an example for 8PSK modulation where the output of MPEG-2 encoder is 2.4 Mbits/sec and the FEC rate is set to a value of 3/5.

$$\text{Symbol-Rate Needed} = \frac{2.4 \text{ Mbit/sec}}{3 \text{ bits/symb} * (3/5) * (0.99506)}$$

$$\text{Symbol-Rate Needed} = \frac{2.4 \text{ Mbit/sec}}{1.791 \text{ bits/symb}}$$

$$\text{Symbol-Rate Needed} = 1.34 \text{ Msymbols/sec}$$

The final formula is for DATV Bandwidth (BW). The “roll-off” factor affecting **BW_{allocation}** for DVB-S2 is 0.2; compared to DVB-S where roll-off is 0.35. For DVB-S2 modulations,

the formula for (allocation) RF BW is:

$$\text{RF BW}_{\text{allocation}} = 1.2 \times \text{Symbol-Rate}$$

Figure 6 shows a spectrum analyser capture of a 1.2 GHz DVB-S2 signal, using 8PSK modulation (13.5MSymb/sec, FEC=3/5, Pilots ON, RollOff = 20%). The Bandwidth shown is about 16.2 MHz.

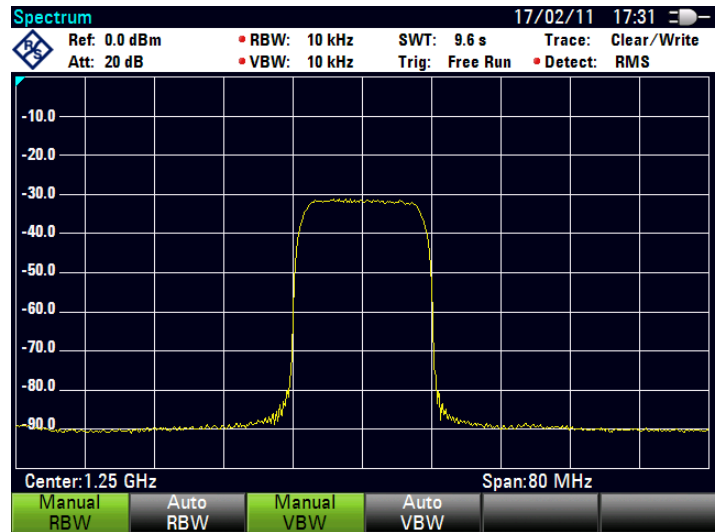

Fig 6 - A DVB-S2 MidiMOD2 exciter 8PSK output transmission is seen on a Spectrum Analyzer (Courtesy of Stefan DG8FAC)

The Net-Data-Bit-Rate (NDBR) capacity that can be supported in a particular bandwidth is listed in **Table 6**. Note that these values do not include the overhead introduced by inserting Pilot Tones for improved receiving robustness.

Receiving DVB-S2

In **Fig 1**, the block diagram shows a typical DVB-2 receiving station used for DATV. The DVB-S2 SetTopBox (STB) can be purchased on e-bay and other online stores here in the USA. The output of many S2 STB’s include: composite video, S-video, component video, and HDMI interfaces. It is interesting to note that the DVB-S2 STB usually will receive old DATV DVB-S transmissions using a “modified 8PSK mode” setting that is backward compatible to DVB-S.

PRO’s and CON’s

Table 7 attempts to compare the strengths and weaknesses of DVB-S2 against DVB-S for Digital-ATV. There is no question that DVB-S2 provides a more robust signal and can pack multiple TS video streams into a small bandwidth. But, most of the DVB-S2 STB receivers currently are not designed to not tune down below 10 MSymb/sec, and so this limitation makes it difficult to receive a signal with a 2 MHz bandwidth.

Table 6 - Net Data Bit-Rates for DVB-S2 at a given RF Bandwidth

Modulation		DVB-S2 RF BANDWIDTH for DATV (RF BW = SymbolRate x 1.2)						
		1.5 MHz (SR = 1.25 MS/sec)	2.0 MHz (SR = 1.67 MS/sec)	2.5 MHz (SR = 2.08 MS/sec)	3.0 MHz (SR = 2.5 MS/sec)	4.0 MHz (SR = 3.33 MS/sec)	5.0 MHz (SR = 4.17 MS/sec)	6.0 MHz (SR = 5.0 MS/sec)
QPSK	FEC Code Rate							
	1/4	0.62	0.83	1.03	1.24	1.65	2.06	2.47
	1/3	0.83	1.10	1.37	1.65	2.20	2.76	3.30
	2/5	0.99	1.33	1.65	1.99	2.64	3.31	3.97
	1/2	1.24	1.66	2.07	2.49	3.31	4.15	4.97
	3/5	1.49	1.99	2.48	2.99	3.98	4.98	5.97
	2/3	1.66	2.22	2.76	3.32	4.42	5.54	6.64
	3/4	1.87	2.50	3.11	3.74	4.99	6.24	7.49
	4/5	1.99	2.66	3.32	3.99	5.31	6.65	7.97
	5/6	2.08	2.78	3.46	4.15	5.53	6.93	8.31
8/9	2.22	2.96	3.69	4.43	5.91	7.40	8.87	
9/10	2.25	3.00	3.74	4.49	5.98	7.49	8.98	
8PSK	3/5	2.24	2.99	3.73	4.48	5.96	7.47	8.96
	2/3	2.49	3.33	4.14	4.98	6.64	8.31	9.96
	3/4	2.81	3.75	4.67	5.61	7.48	9.36	11.23
	5/6	3.12	4.16	5.18	6.23	8.30	10.39	12.46
	8/9	3.33	4.44	5.53	6.65	8.86	11.10	13.30
	9/10	3.37	4.50	5.60	6.74	8.97	11.23	13.47
16APSK	2/3	3.32	4.43	5.52	6.63	8.84	11.07	13.27
	3/4	3.74	4.99	6.22	7.47	9.95	12.46	14.94
	4/5	3.99	5.33	6.64	7.98	10.64	13.32	15.97
	5/6	4.15	5.55	6.91	8.31	11.07	13.86	16.62
	8/9	4.43	5.92	7.38	8.87	11.81	14.79	17.74
	9/10	4.49	6.00	7.47	8.98	11.96	14.98	17.96

(NOTE-1: NTSC Analog Camera produces about 2.1 to 2.4 Mbps-per-sec of MPEG-2 output for Ham Radio type broadcasts)

(NOTE-2: The Net Data Bit-Rate values inside the Table need to be at 2.4 Mbps or larger to support the expected camera data rate coming from MPEG-2 encoder)

(NOTE-3: The Net Data Bit-Rate values inside the Table shown in RED (with strikethrough) are Net Data Bit-Rates that will not support the video data stream of 2.4 Mbps/sec.)

(NOTE-4: The Net Data Bit-Rate values are based on using a DVB-S2 FEC FRAME length of 64,800 bits.)

(NOTE-5: 16APSK and 32APSK modulations are currently not used for commercial TV broadcasts. 16APSK is shown only for comparison.)

Table 7 – Comparing DVB-S2 with DVB-S

	DVB-S2	DVB-S
PROs	Quasi-Error-Free operation at about 0.7dB to 1 dB from the Shannon limit 1xTS Bandwidth can be as small as 1 or 1.5 or 2 MHz with 8PSK Cheap Set Top Boxes (STB) on eBay and online 3 MHz bandwidth can support multiple video streams	1xTS Bandwidth can be as small as 2 or 3 MHz Cheap FTA Set Top Boxes (STB) on eBay Wide-spread experience and knowledge is provided by European hams on the Internet Newer DVB-S2 STB will receive DVB-S
CONs	Most DVB-S2 STB receivers will only tune down to 10 MSymbol/sec (12 MHz bandwidth) Currently DVB-S2 exciter board is 100% more expensive than DVB-S	QPSK modulation requires larger bandwidth than 8PSK modulation

Conclusion

I am not yet convinced that DVB-S2 is the correct technology direction for ham D-ATV. Most new features provided by DVB-S2 technology (like “news gathering” and “data content trunking”) are not of much interest to ham DATV. My main DATV interest is fitting narrow DATV 1xTS bandwidth into crowded ham band spectrum plans. I can envision placing three 2 MHz DATV repeater signals into the band space that used to be occupied by a single 6 MHz analog ATV signal. But, the STB inability to tune in a 1.5 MHz signal...blocks my goal. Certainly DVB-S2 can provide a great technology for multiple video streams that can be used by DATV repeater operators.

KD6ILO REPEATER DETAILS

This repeater unit can operate as a fixed base, mobile or portable Amateur Television repeater and can be set up in less than 30 minutes depending on set up configuration. It was built for Emergency Communications (EMCOMM) support for ARES, RACES and CERT etc. It was built back in 2007 when I was still living in Washington State and active in ARES and RACES. It uses an ATVC-4 repeater controller and a OSD-ID PC board housed together in a aluminum project box. The unit also carries three receiver units, input 1 for the 23cm AM receiver unit for the 1289.25 MHz input, input 2 -

A dual-band FM receiver unit for the 33cm 915.0 MHz input and 23cm 1280.0 MHz input and input 3 - for the 13cm FM receiver unit for the 2398.0 MHz input. Input number 4 used for the audio/video input signal for repeater linking using an Internet connection. Input 5 video input for the repeater ID, the audio input on five is used for the repeaters (DTMF control

operation) control radio (using an Vertex Standard , dual-band (VHF/UHF) transceiver) which also acts as a voice X-band repeater. This unit has a dual purpose when it comes to operation. Output transmitter is a 70 cm Videolynx, Model VM-70X (set on an output frequency of 426.25 MHz) at 2.5 watts connected to a MIRAGE D-1010 for an output power of 60 watts P.E.P. For close in repeater support (within 5 miles or closer) the RF amplifier is not used. Also the units three receiver units have alternate receive frequencies (can be changed by dip-switches) as needed as it is moved around in different states, county's or operational areas as not to interfere with other fixed base/site ATV repeaters. Some goes for the repeaters output frequency on the 70cm transmitter it has three alternate output frequencies which also can be change by dip-switch. All this built in to a PELICAN case for easy transport and setup. It also has a video/audio output connection for an Internet stream to BATC.TV. When this repeater is set up portable along side an emergency communications vehicle with provides a broadband satellite connection, it can know provide a video/audio interface between ATV over the air RF signals (to the Internet) which know can be sent to an outside the range of a EOC outside the affected area or around the world if needed. This repeater can be remotely control by using DTMF or the Internet.



REPEATER REPORT FROM EUROPE

DATV repeater ON0OB in 70 cm band

The DATV repeater ON0OB is located in Oudenaarde, Belgium (JO10TT) and operates on 436.000 MHz.

The DVB-S standard has been chosen in consideration of the cost effective availability of digital satellite broadcast receivers. These receivers usually operate from 950 MHz to 2150 MHz and frequency conversion is easy. For ON0OB, up-conversion from 436 MHz to 1336 MHz is implemented.

A major advantage of DATV, in comparison with former analog ATV transmitters, is the low signal strength needed. For a "perfect" analog ATV image, a signal to noise ratio of at least 20 dB is needed. With DATV this is reduced to 8 dB S/N.

We have chosen to reduce the bandwidth as far as compatible with a very comfortable image quality. Modulation is QPSK with a symbol rate of 2.000 kSym. This corresponds to a data stream of 4 Mb/s. Total bandwidth is 2.68 MHz at -3dB (including video, audio and teletext information).

The choice of a low symbol rate limits the speed of quick moving images (freezing), but for normal quiet video there is no problem. The symbol rate has no influence on the image quality, only on the speed needed for image refreshing.

The power amplifier of a DATV transmitter needs to be class A, with high linearity. This limits the power somewhat. At ON0OB, the output power is 25 Watt, delivered by a PA of 100 Watt (class C = 25% efficiency).

ON0OB is at 85 m ASL, with antennas 21 meters above ground, so that total ASL is 106 m. Antenna gain is 9 dBi. Under normal circumstances, without "conditions", perfect reception is observed up to 70 - 80 km distance.

...Julien Goethals - ON6GJ, builder of and responsible for the ON0OB repeater. Translation by Gaston Bertels - ON4WF

NEWS FLASH! WY8G WILL HAVE AN ATV SIGNAL SOON!

On a warm Friday morning in the middle of March, KA8MFD, KA8LWR, and W8URI showed up at WY8G's QTH to help with an antenna installation. Bruce has become interested in ATV and decided to put up a 439 and 147 MHz antenna. The following pictures show his installation. The antennas that were put up are seen at the lower portion of the pictures. **Bruce's tower is 185 feet high** (1394 feet above sea level). The antennas were installed at about the 80 foot level. Look forward to seeing him in the near future. Article and pictures submitted by W8URI with permission of Bruce, WY8G.



KA8MFD INSTALLS NEW ANTENNA

Ross, KA8MFD just got a major antenna upgrade. The install took place on Feb 19, 2011 about noon with the temperature about 37 degrees (Brave person!!!). The left photo shows Ross taking down the 439 antenna in its temporary position at 6 feet above ground. He was able to see the Columbus repeater P1 at that level. He was also able to see WB8LGA, KA8LWR, and W8URI. His antenna is now at about 40 feet and Columbus is now about P3 to P4 depending on conditions. The install also included a 1200 MHz antenna. Ross is located in the thriving metropolis of Edison, Ohio which is just west of Mount Gilead. He continues to make improvements on all bands and currently streams video on BATC. Look for him to be on soon with us on Tuesday nights! Article with permission of KA8MFD. (PS. I was there for general nuisance and vocal support).
...W8URI

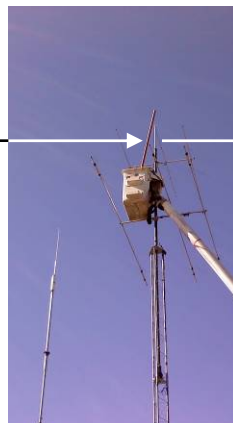

HAM RADIO TERMS GLOSSARY

Here's a collection of words often used by Hams. It's important that we use them properly so I've taken the time to explain them. If any of you have more to add to the list, let me know.

Acid core solder – Solder wire using LSD for flux.

Admittance – A characteristic of a radio amateur who acknowledges mistakes.

Autopatch – The process of refurbishing sheet metal on vehicles.

Anti-static strap – Conductive strap tightly worn around the mouth of a quarrelsome person. Also a lightning proof athletic supporter.

Amplifier – A circuit which magnifies signal strength, that has reached combustion temperature.

Continuous wave – Uninterrupted kindred gesturing.

Desense – A French phrase referring to pennies.

Desoldering – Removal of grassy turf.

Dielectric – A mode of expiration by means of electrocution.

Distributed capacitance – Capacitor handed out to a group.

Field day – Spending time in the north forty.

Ground Plane – Metallic chips from recycled aircraft. Also a plane that “flies” down the highway.

Ground radials – Recycled tires.

Guy wires – Support cables of male orientation. Also suspenders.

Half-wave – A salutation from a person not especially exuberant.

Ham Band – A musical group comprised of amateur radio operators.

Heterodyning – A meal attended by both sexes.

Kilocycle – A two wheeled vehicle, in which is hidden illegal drugs.

Kilowatt – A thousand questions.

Low Noise Preamp – Three Ameco nuvistor preamps connected in series. (Names have been omitted to protect the innocent!!!!)

Main Lobe – Beer gut. (This one gets a little personal!)

Microwave – A very small salute.

Net night – Seine fishing after dark.

Ohmmeter – One who eats ohms.

Over sampling – A phenomena that often takes place at pot luck dinners

Packet Radio – A transceiver that comes in a very small envelope.

Rectifier – Painful phenomenon that occurs when the lowest section of the lower intestine reaches combustion temperature.

Rise time – A period of awakening, often extended the morning after Field Day.

Semi conductor – Subordinate attendant on domestic passenger rail service.

Side lobes – Sometimes called “love handles”. (Also personal.)

Silicon – A jubilant felon.

Slow scan television – Television that won't quickly change channels.

Speech clipper – A source of interruption at a radio club presentation. (Dayton is coming!!!)

Spread spectrum – The entire range of semi-solid foods applied to bread and toast.

Shortwave – A kindred gesture of very brief duration.

Time delay generator - Engine driven AC power plant that won't start. Also – my wife when we are getting ready to go away!

Tracking generator – Complex machine that produces steel rail.

Transponders – Those who have traveled across very small bodies of water.

Vacuum capacitor – The act of cleaning a capacitor.

MORE TV STATIONS MOVING TO UHF

The FCC released a listing of [Broadcast Station Totals as of December 31, 2010](#). The number of full-power VHF TV stations continues to decline. As of June 30, 2010 there were 1,021 commercial UHF TV station licenses and 372 commercial VHF TV stations. As of December 31, 2010, these numbers changed to 1,022 and 368. The total number of full power TV stations dropped by three, as there was only one new UHF license. The number of educational TV stations (VHF and UHF) was unchanged during the last six months.

The change from the period before the DTV transition is dramatic. As of Dec. 31, 2008, there were 582 VHF commercial TV stations and only 786 UHF commercial TV stations. Commercial and educational TV stations totaled 1,759 then, as compared to the 1,781 on Dec. 31, 2010. At the end of 2010, there were 9,021 full-power, low-power, Class A, and TV translators licensed. This compares with 9,064 a year ago, when there were 195 more UHF and VHF low power TV stations licenses.

The numbers indicate that while low-power TV licenses have decreased, possibly due to a reduced number of channels available with the reallocation of channels 52-69, interest in full-power TV and TV transmitters remains strong as shown by the number of licenses.

It will be interesting to see what the numbers look in a year or two if the incentive auctions proposed by the FCC are approved and

conducted. To view broadcast license totals for other dates, see [Broadcast Station Totals \(Index\) 1990 to Present](#).

ATCO SATURDAY BREAKFAST

Below is an illustration of the typical Saturday breakfast get together among ATCO members and friends. We try to change restaurants each week to mix it up a little and also to find new ones that could give us better food and service. We discuss the next place each Tuesday during our 147.48 net and then arrive at the selected restaurant about 8AM the following Saturday morning.

Join us if you can because if you're not there, **you're the one we talk about!**



RECON ROBOT IS BACK IN THE NEWS

WP Docket No. 08-63, Recon Robotics Inc. ATV outfitted part 90 robot scouts for police and homeland security is back in the news. As most of you know the ARRL, ATN, ATCO, ATVQ and many other Ham groups had commented and objected to allowing the 1 watt (peak sync) three channel 430-450 MHz band robots to be deployed.

The FCC had approved the request but additional objections and challenges were made by the league and the Ham radio community. The FCC on April 13th modified the report and order (released April 15th) to reflect some of the concerns while tossing others, this modification is retroactive.

The main changes are in both the FCC certification tags on the devices and operation manuals to say this device cannot interfere with and must accept interference from both federal and non federal (Hams) licensed stations in the 430-450 MHz band (see sections 14, 15, and 16).

At least that should stop law enforcement from coming to your house and trying to arrest you for causing QRM to their operations and allow us some protection if we get QRM. The channels are as follows, an agency's first channel allocation is 436-442 MHz with visual carrier at 437.25 MHz. The second channel allocation, if they already have a channel 1 device, is 442-448 MHz with video carrier at 443.25 MHz, and the third channel, if the agency already has devices on channels 1 and 2, is 430-436 MHz visual carrier on 431.25 MHz.

Channel 1 would cause herringbone on 434 MHz and 439.25 MHz lower VSB stations. Some satellite users may hear the visual carrier within the satellite sub band and think it is ATV. Channel 2 would cause herringbone to 439.25 upper VSB stations and cause sync buzz to voice repeater inputs within about 200 KHz of 443.25 MHz and think it is ATV. Channel 3 would cause some ghosting of the robot's video over 434 MHz pictures but no herringbone unless they have an aural carrier (most likely at 435.75 MHz) but the visual carrier may cause sync buzz to 432 MHz weak signal mode stations.

ATV receiving QRM would likely be seen if the robot is very close to the ATV receiving station as they would be used in a building. If used outdoors, the range would be better but do not expect them to be any better than a typical helmet camera with a 1 watt transmitter. The weak signal, FM and satellite mode users may hear the sync buzz and think ATV is the cause, have the visual carrier frequencies above handy in case you receive QRM complaints.

...Mike WA6SVT

HERE COMES COMMODORE!

The Commodore 64 is back in production! This is not the 64 of 20+ years ago, although it is in the same size package and very useful for ATV graphics, it has been fully modernized with today's electronics. The proposed price is \$595 see commodoreusa.net for details but just to get you in the mood to go out and get one here is a glimpse into the new upgrade. CPU is a dual Intel with Nvidia 2 graphics, 2GB Ram upgraded to 4 GB, DVD read/write upgraded to Blu-ray, plays DVD and Blu-ray movies and games, USB ports and more. ...Mike WA6SVT

HAMVENTION FRIDAY NIGHT DINNER SCHEDULE

The ATV Friday night dinner and discussion will be held on Hamvention Friday from 7 till 10PM at Roush's Restaurant 305 W Main St. in Fairborn, OH 45324 (at the north end of Wright Patterson airfield runway). The dinner menu is varied, moderately priced and ordered separately. We will enjoy a sit down dinner, speakers talk about various ATV topics and door prizes for those present. All present and future ATVers are welcome to join us.

Directions: Take I-75 north then I-70 east. Exit SR 235/ SR4 south (Fairborn exit). South on 235 about 1 mile then left on Chambersburg Road (east & still SR235 past airport runway). Right on N. Broad Street for about 10 blocks. Turn left on W. Main Street for 3 blocks to Miller Ave. Roush's is on corner of W. Main and Miller. Parking in rear. Roush's Restaurant. 305 W. Main street, Fairborn, OH 1-937-878-3611 GPS (39-49-19-N) X (84-01-30-W)

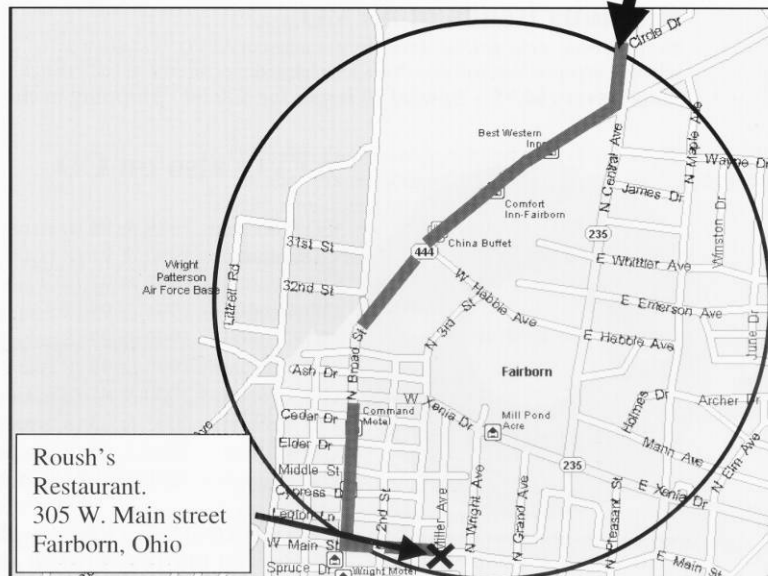
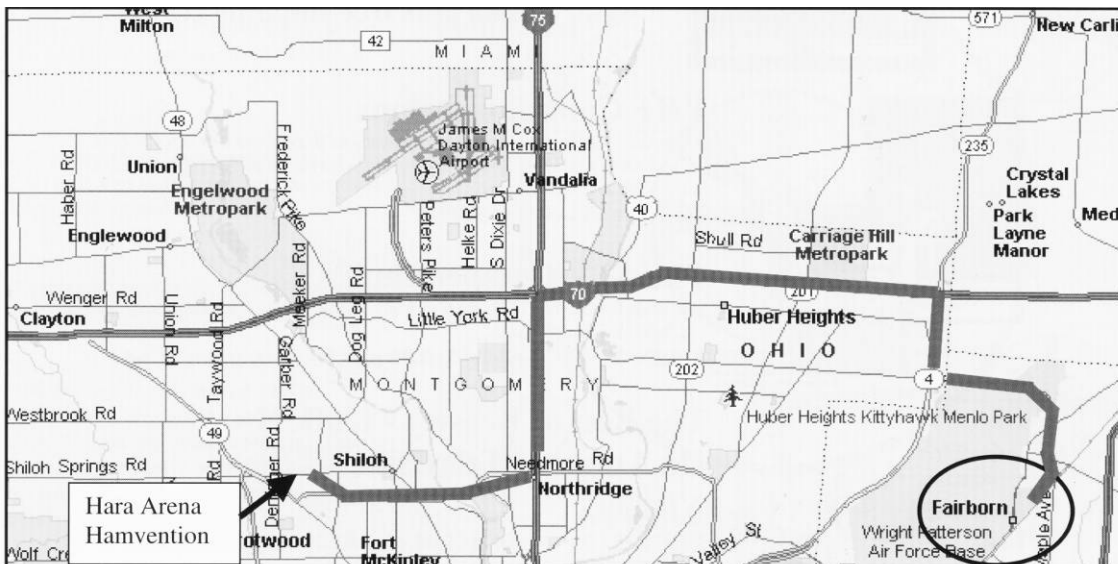

ATCO

2011 SPRING EVENT

1 PM – SUNDAY

MAY 1, 2011

ABB PROCESS AUTOMATION

CAFETERIA

579 EXECUTIVE CAMPUS DRIVE

FOR MORE DETAILS, CONTACT

ART – WA8RMC - 891-9273

LUNCH PROVIDED – DOOR PRIZES

BRING A FRIEND AND SEE OLD BUDDIES

MINI HAMFEST – SHOW AND TELL

DIRECTIONS TO THE ATCO EVENT

From I-70 WEST Bound:

Take I-270 Northbound around and turning to the west to Cleveland Ave. Exit north onto Cleveland Ave and travel north about 2 miles to Executive Campus drive. (It's the next street past Westar Crossing Street). Turn left (west) to the ABB building at the end of the street.

From I-70 EAST Bound:

Take I-270 Northbound around and turning to the east past SR 315 and past I-71. Get off on the Cleveland Ave second exit and travel north (to Westerville). Continue north on Cleveland past Schrock road and then past Main Street. Continue north about ½ mile past Main Street to Executive Campus Drive. (It's the next street past Westar Crossing Street) Turn left (west) to the ABB building at the end of the street

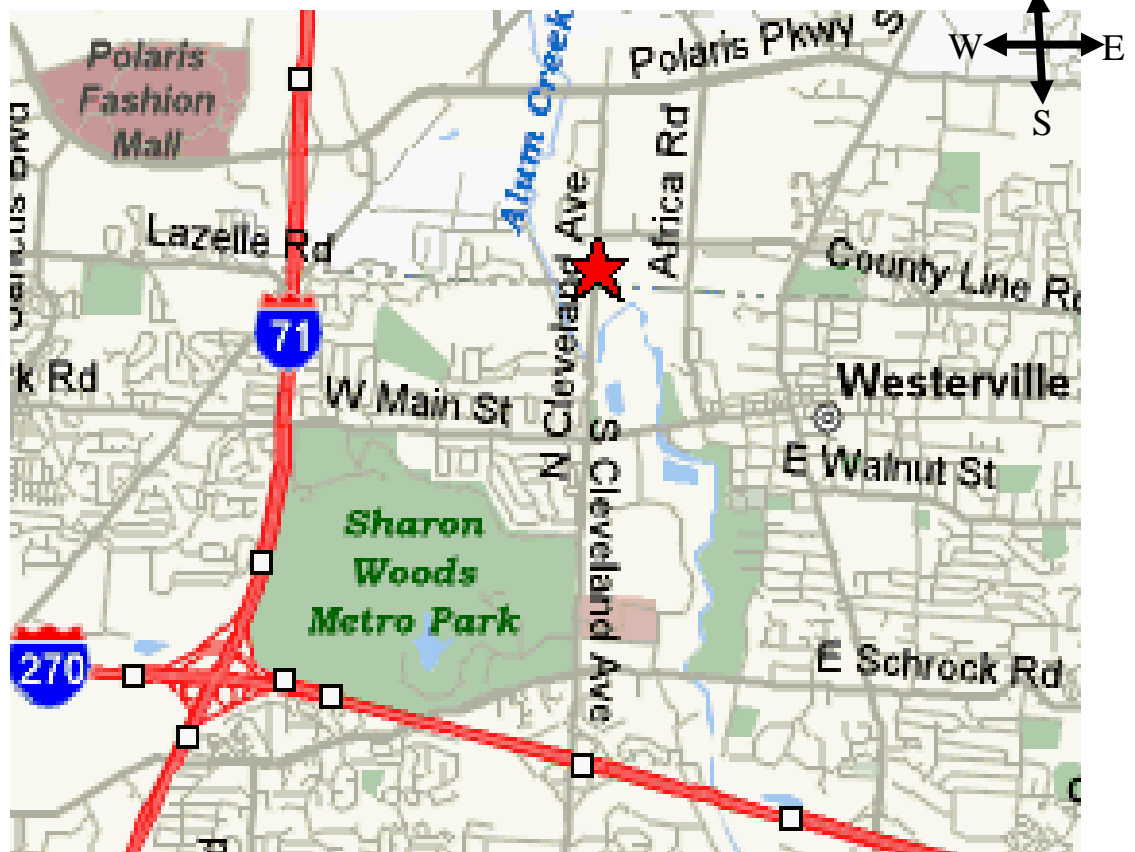

From I-71 NORTH bound toward Columbus:

Drive through Columbus on I-71 to I-270 on the north side. Take I-270 east to the first exit, Cleveland Ave. Get off the Cleveland Ave second exit and travel north (to Westerville). Continue north past Schrock road and then past Main street. Continue north about ½ mile past Main Street to Executive Campus Drive. (It's the next street past Westar Crossing Street) Turn left (west) to the ABB building at the end of the street.

From I-71 traveling SOUTH bound toward Columbus (North of I-270):

Exit the Polaris Ave exit and travel East about 1 mile to Cleveland Ave. Turn right on Cleveland Ave to Executive Campus Drive. Turn right again on Executive Campus Drive. ABB is on the right side of the street about half way around the semi-circle.

LOCAL HAMFEST SCHEDULE

This section is reserved for upcoming Hamfests. They are limited to Ohio and vicinity easily accessible in one day. Anyone aware of an event incorrectly or not listed here; notify me so it can be corrected. This list will be amended, as further information becomes available. To see additional details for each Hamfest, Control Click on the blue title and the magic of the Internet will give you the details complete with a map!

...WA8RMC.

04/23/2011 | [Jackson County ARC Swap](#)

Location: Jackson , OH

Sponsor: Jackson County Amateur Radio Club

Website: <http://jacksoncountycastle.org/index.html>

05/01/2011 | [Athens Hamfest 2011](#)

Location: Athens, OH

Sponsor: Athens County Amateur Radio Association

Website: <http://ac-ara.org/>

05/20/2011 | [Dayton Hamvention](#)

Location: Dayton, OH. Hara Arena 1001 Shiloh Springs Road Dayton, OH 45401

Sponsor: Dayton Amateur Radio Association Talk-In: 146.94- or 146.64- Phone: 937-276-6930 Email: info@hamvention.org

Website: <http://www.hamvention.org/>

06/18/2011 | [Milford Hamfest](#)

Location: Milford, OH

Sponsor: Milford Amateur Radio Club

Website: <http://www.w8mrc.com>

06/04/2011 | [Fulton County ARC Hamfest & Tailgate Party](#)

Location: Tedrow, OH

Sponsor: Fulton County Amateur Radio Club

Website: <http://k8bxq.org>

07/16/2011 | [NOARSFEST](#)

Location: Elyria, OH

Sponsor: Northern Ohio Amateur Radio Society

Website: <http://noars.net>

07/17/2011 | [Van Wert Amateur Radio Club Hamfest](#)

Location: Van Wert, OH

Sponsor: Van Wert Amateur Radio Club

Website: <http://www.w8fy.org>

07/31/2011 | [Portage Hamfair '11](#)

Location: Randolph, OH

Sponsor: Portage Amateur Radio Club

Website: <http://hamfair.com>

08/06/2011 | [Columbus Ohio Hamfest](#)

Location: Columbus, OH

Sponsor: Voice of Aladdin ARC (W8FEZ)

Website: <http://www.aladdinshrine.com/hamfest.htm>

NEW MEMBER(S)

Let's welcome the new members to our group! If any of you know anyone who might be interested, let one of us know so we can flood him or her with information. New members are our group's lifeblood. It's important that we actively recruit new faces aggressively. None this time.

...WA8RMC

INTERNET ATV HOME PAGES (list verified 01/14/11)

Domestic homepages

http://www.atco.tv	Ohio, Columbus, homepage (ATCO)
http://www.w8bi.org/atv/atvresources.html	Ohio, Dayton ATV group (DARA)
http://www.citynight.com/atv	California, San Francisco ATV
http://atn-tv.org/ATN.htm	California, Amateur Television Network in Central / Southern
http://members.tripod.com/silatvg	Illinois, Southern, Amateur Television group
http://www.ussc.com/~uarc/utah_atv/id_atv1.html	Idaho ATV
www.bratsatv.org	Maryland, Baltimore Radio Amateur Television Soc. (BRATS)
www.qsl.net/k7atv/	Salem, Oregon Amateur Television Associations-Salem
http://www.qsl.net/kd2bd/atv.html	New Jersey, Brookdale ARC in Lincroft
http://www.ipass.net/~teara/menu3.html	North Carolina, Triangle Radio Club (TEARA)
http://www.oregonatv.org	Oregon, Portland OATVA Oregon Amateur TV Association
?	Pennsylvania, Pittsburg Amateur Television
http://members.bellatlantic.net/~theoikat/	Pennsylvania, Phila. Area ATV
?	Texas, Houston ATV (HATS)
http://www.hotarc.org/atv.html	Texas, WACO Amateur TV Society (WATS)
?	Utah ATV
www.qsl.net/ww7ats	Washington, Western Washington Television Soc. (WWATS)
http://www.shopstop.net/bats/	Wisconsin, Badgerland Amateur Television Society (BATS)

Foreign homepages

http://atv.hamradio.si	Slovenia ATV
http://www.batc.tv	British ATV club (BATC)
http://www.cq-tv.com	British ATV Club and CQ-TV Magazine
	Finland ATV, OH3TR repeater.
	German ATV

Misc other ATV related sites

http://www.atv-tv.org	The Amateur Television Directory
http://www.atn-tv.org	Amateur Television Network
http://www.atvquarterly.com	Amateur Television Quarterly Magazine
http://gb3lo.camstreams.com	"GB3LO" Repeater Camstream westoft, UK
http://www.ham-radio.com/sbms	"SBMS" San Bernardino Microwave Society
http://www.qsl.net/kc6ccc/	"METS" Microwave Experimenters Television System

TUESDAY NITE NET ON 147.48 MHz SIMPLEX

Every Tuesday night @ 9:00PM WA8RMC hosts a net for the purpose of ATV topic discussion. There is no need to belong to the club to participate, only a genuine interest in ATV. All are invited. For those who check in, the general rules are as follows: Out-of-town and video check-ins have priority. A list of available check-ins is taken first then a roundtable discussion is hosted by WA8RMC. After all participants have been heard, WA8RMC will give status and news if any. Then a second round follows with periodic checks for late check-ins. We rarely chat for more than an hour so please join us if you can.

ATCO TREASURER'S REPORT - de N8NT

OPENING BALANCE (01/16/11).....	\$1874.53
RECEIPTS(dues).....	\$ 170.00
Paypal test receipt.....	\$ 34.73
Paypal fee.....	\$ (7.30)
Bank service fee reversal.....	\$ 12.00
CLOSING BALANCE (04/16/11).....	\$2083.96

ATCO REPEATER TECHNICAL DATA SUMMARY

Location: Downtown Columbus, Ohio
Coordinates: 82 degrees 59 minutes 53 seconds (longitude) 39 degrees 57 minutes 45 seconds (latitude)
Elevation: 630 feet above average street level (1460 feet above sea level)
TV Transmitters: 427.25 MHz AM mod, 1258 MHz FM mod, 1268 MHz QPSK digital, 2433 MHz FM mod, and 10.350 GHz FM mod.
multipole filters in output line of all transmitters
Output Power - 427.25 MHz: 50 watts average 100 watts sync tip
1258 MHz: 40 watts continuous (Analog ATV)
1268 MHz: 20 watts continuous (DVB-S digital ATV - 2 channels)
2433 MHz: 15 watts continuous
10.350 GHz: 1 watt continuous
Link transmitter - 446.350 MHz: 5 watts NBFM 5 kHz audio
Identification: 427, 1258, 1268, 2433, 10.35 GHz transmitters video identify every 30 min. with ATCO & WR8ATV on 6 different screens.
1268 MHz & 10.35 GHz - Continuous transmission of ATCO & WR8ATV with no input signal present
Transmit antennas: 427.25 MHz - Dual slot horizontally polarized "omni" 7 dBd gain major lobe east/west, 5dBd gain north/south
1258 MHz - Diamond vertically polarized 12 dBd gain omni (Analog ATV)
1268 MHz - Diamond vertically polarized 12 dBd gain omni (Digital DVB-S ATV)
2433 MHz - Comet Model GP24 vertically polarized 12 dBd gain omni
10.350 GHz - Commercial 40 slot waveguide horizontally polarized 16 dBd gain omni
Receivers: 147.48 MHz - F1 audio input with touch tone control
439.25 MHz - A5 video input with FM subcarrier audio (lower sideband)
449.975 MHz - F1 audio input aux touch tone control. (An input here generates an output on 147.48 and 446.350).
1280 MHz - F5 video input or DVB-S digital (digital input fed direct to 1268 MHz digital output channel 2)
2398 MHz - F5 video input
10.450 GHz - F5 video input (not installed yet)
Receive antennas: 147.48 MHz - Vert. polar. Diamond 6dBd dual band (also used for 446.350 MHz link output)
439.25 MHz - Horizontally polarized dual slot 7 dBd gain major lobe west
1280 MHz - Diamond vertically polarized 12 dBd gain omni
2398 MHz - Comet Model GP24 vertically polarized 12 dBd gain omni
10.450 GHz - Commercial 40 slot waveguide horizontally polarized 16 dBd gain omni (not installed yet)

Input control: Touch Tone Result (if third digit is * function turns ON, if it is # function turns OFF)
00* turn transmitters **on** (enter manual mode-keeps xmitters on till 00# sequence is pressed)
00# turn transmitters **off** (exit manual mode and return to auto scan mode)
264 Select Channel 4 Doppler radar. (Stays up for 5 minutes) Select # to shut down before timeout.
697 Select Time Warner radar. (Stays up till turned off). Select # to shut down.

Manual mode functions: 00* then 1 for Ch. 1 Select 439.25 receiver
00* then 2 for Ch. 2 Unused at this time
00* then 3 for Ch. 3 Select 1280 receiver
00* then 4 for Ch. 4 Select 2411 receiver
00* then 5 for Ch. 5 Select video ID (4 identification screens)

01* or 01# Channel 1 439.25 MHz scan enable (hit 01* to scan this channel & 01# to disable it)
02* or 02# Channel 2 (not in use at this time)
03* or 03# Channel 3 1280 MHz scan enable
04* or 04# Channel 4 2398 MHz scan enable
A1* or A1# Manual mode select of 439.25 receiver audio
A2* or A2# Unused channel at this time
A3* or A3# Manual mode select of 1280 receiver audio
A4* or A4# Manual mode select of 2398 receiver audio
C0* or C0# Beacon mode – transmit ID for twenty seconds every ten minutes
C1* or C1# C1* to disable 427 MHz transmitter, C1# to enable it
C2* or C2# C2* to disable digital transmitter, C2# to enable it

ATCO MEMBERS AS OF April 2011

Call	Name	Address	City	St	Zip	Phone
KD8ACU	Robert Vieth	3180 North Star Rd	Upper Arlington	OH	43221	614-457-9511
KC3AM	Dave Stepnowski	735 W Birchtree Ln	Claymont	DE	19703	
AH2AR	Dave Pelaez	1348 Leaf Tree Lane	Vandalia	OH	45377	
W8ARE	Larry Meredith III	6070 Langton Circle	Westerville	OH	43082-8964	
KC8ASF	Tom Pallone	3437 Dresden St.	Columbus	OH	43224	614-268-4873
KC8BTX	Dudley Field	357 N. Ridge Heights Dr	Howard	OH	43028	
W6CDR	Wynn Rollert	1141 Pursell Ave	Dayton	OH	45420	937-256-1772
WB8CJW	Dale Elshoff	8904 Winoak Pl	Powell	OH	43065	614-210-0551
N8COO	C Mark Cring	3941 Three Rivers Lane	Groveport	OH	43125	614-836-2521
N8CXI	Garry Cotter	2367 Northglen Drive	Columbus	OH	43224	
N9CX	Bill Erwin	231 Gateside Ct.	Gahanna	OH	43230	
WA2CZD	Jim Gilbert	1204 Aspen Pines Drive	Wilder	KY	41071-0404	
N3DC	William Thompson	6327 Kilmer St	Cheverly	MD	20785	
WA8DNI	John Busic	2700 Bixby Road	Groveport	OH	43125	614-491-8198
K8DMR	Ron Fredricks	8900 Stonepoint Ct	Jennison	MI	49428-8641	
W8DMR	Bill Parker	2738 Florbunda Dr	Columbus	OH	43209	
K8DW	Dave Wagner	2045 Maginnis Rd	Oregon	OH	42616	419-691-1625
WB8DZW	Roger McEldowney	5420 Madison St	Hilliard	OH	43026	614-876-6033
KC8EVR	Lester Broadie	108 N Burgess	Columbus	OH	43204	
N8FRT	Tom Flanagan	1751 N Eastfield Dr.	Columbus	OH	43223	
WA8FLY	Rod Shaner	16012 London Rd.	Orient	OH	43146	740-279-3614
W8FTX	George Biundo	3675 Inverary Drive	Columbus	OH	43228	614-274-7261
W8FZ	Fred Stutske	8737 Ashford Lane	Pickerington	OH	43147	
KB8GHW	Mike Amirault	5560 Refugee Rd.	Baltimore	OH	43105	614-859-7005
WA8HFK,KC8HIP	Frank & Pat Amore	3630 Dayspring Dr	Hilliard	OH	43026	614-777-4621
W4HTB	Henry Cantrell	905 Wrenwood Dr.	Bowling Green	KY	42103	270-781-9624
WG8I	Chris Vojsak Sr,	3536 W Henderson Rd	Columbus	OH	43220-2232	614-203-6000
WB2IIR	Michael Anthony	370 Georgia Drive	Brick	NJ	08723	
N8IJ	Dick Knowles	1799 Homeward Ave	Lima	OH	45805	
KD8JLO	David Nulter	510 Millag Drive	Sunbury	OH	43074	614-579-6425
K8KDR,KC8NKB	Matt & Nancy Gilbert	5167 Drumcliff Ct.	Columbus	OH	43221-5207	614-771-7259
N9KNV	Edmund Janowski	1721 Minnesota Ave	South Milwaukee	WI	53172	
W8KHW	Kevin Walsh		Columbus	OH	43220	614-442-7748
WA8KQQ	Dale Waymire		Greenville	OH	45331	937-548-2492
N8LRG	Phillip Humphries	3226 Deerpath Drive	Grove City	OH	43123	614-871-0751
WB8LGA	Charles Beener	2540 State Route 61	Marengo	OH	43334	
KA8LWR	Mel Alberty	1645 Olentangy Road	Bucyrus	OH	44820	419-468-2971
W8MA	Phil Morrison	154 Llewellyn Ave	Westerville	OH	43081	
KA8MID	Bill Dean	2630 Green Ridge Rd	Peebles	OH	45660	
W0MNE	Mike Doty	4300 Winchester Southern Rd	Circleville	OH	43113	740-420-9060
N8NT	Bob Tournoux	3569 Oarlock Ct	Hilliard	OH	43026	614-876-2127
N00BG	Jim Conley	33 Meadowbrook C C Est	Ballwin	MO	63011	
W80BT	Tom Camm	63 Goings Lane	Reynoldsburg	OH	43068	740-964-6881
WU8O	Tom Walter	15704 St Rt 161 West	Plain City	OH	43064	614-733-0722
N8OCQ	Bob Hodge Sr.	3750 Dort Place	Columbus	OH	43227-2022	
KB8OFF	Jess Nicely	742 Carlisle Ave	Dayton	OH	45410	
KG4OPZ,KG4OQA	Dave,MaryHolt Schneider	7 Akal Court	Durham	NC	27713	
W6ORG,WB6YSS	Tom, Maryann O'Hara	2522 Paxson Lane	Arcadia	CA	91007-8537	626-447-4565
KE8PN	James Easley	1507 Michigan Ave	Columbus	OH	43201	614-421-1492
W8PU	Gary Poland	3347 S.R. 28	Midland	OH	45148	
KC8QJR	Adam Burley	1796 Queensbridge Drive	Columbus	OH	43235	614-886-2326
WA8RMC	Art Towsee	180 Fairdale Ave	Westerville	OH	43081	614-891-9273
W8RRF	Paul Zangmeister	10365 Salem Church Rd	Canal Winchester	OH	43110	
W8RRJ	John Hull	580 E. Walnut St.	Westerville	OH	43081	614-882-6527
W8RUT,N8KCB	Ken & Chris Morris	2895 Sunbury Rd	Galena	OH	43021	
W8RVH	Richard Goode	9391 Ballentine Rd	New Carlisle	OH	45334	937-964-1185
W8RQI	Ray Zeh	2263 Heysler Rd	Toledo	OH	43617	
KB8RVI	David Jenkins	1941 Red Forest Lane	Galloway	OH	43119	614-878-0575
W8RWR	Bob Rector	135 S. Algonquin Ave	Columbus	OH	43204-1904	614-276-1689
W8RXX,KA8IWB	John & Laura Perone	3477 Africa Road	Galena	OH	43021	614-579-0522
W8SJQ	Rocky Eramo	795 Riverbend Ave	Powell	OH	43065	614-207-2740
W8SJV, KA8LTG	John & Linda Beal	5001 State Rt. 37 East	Delaware	OH	43015	740-369-5856
KB8SSH	Mike Cotts	3424 Homecroft Dr	Columbus	OH	43224	614-371-7380
W3SST	John Shaffer	6706 Gilette Dr	Reynoldsburg	OH	43068	614-751-0029
WA6SVT	Mike Collis	PO Box 1594	Crestline	CA	92325	
W8TIP	Gene Hawkins	1720 Liberty Street	Toledo	OH	43605	
K8TPY, K8FRB	Jeff & Dianna Patton	3886 Agler Road	Columbus	OH	43219	
NR8TV	Dave Kibler	243 Dwyer Rd	Greenfield	OH	45123	937-981-1392
W8URI	William Heiden	5898 Township Rd #103	Mount Gilead	OH	43338	419-947-1121
KB8UWI	Milton McFarland	115 N. Walnut St.	New Castle	PA	16101	
WA8UZP	James R. Reed	818 Northwest Blvd	Columbus	OH	43212	614-297-1328
N8WAC	Tony Everhardt	6512 Emch Road	Walbridge	OH	43465	419-666-5178
KB8WBK	David Hunter	45 Sheppard Dr	Pataskala	OH	43062	740-927-3883
KC8WRI	Tom Bloomer	PO Box 595	Grove City	OH	43123	
AA8XA	Stan Diggs	2825 Southridge Dr	Columbus	OH	43224-3011	

Call	Name	Address	City	St	Zip	Phone
N8XYJ	Dan Baughman	4269 Hanging Rock Ct.	Gahanna	OH	43230	
KB8YMQ	Jay Caldwell	4740 Timmons Dr	Plain City	OH	43064	
KC8YPD	Joe Ebright	3497 Ontario St	Columbus	OH	43224	
N8YZ	Dave Tkach	2063 Torchwood Loop S	Columbus	OH	43229	614-882-0771
N8ZM	Tom Holmes	1055 Wilderness Bluff	Tipp City	OH	45371	
K3ZKO	Ron Cohen	915 Rowland Ave	Cheltenham	PA	19012	215-828-1263
KA8ZNY,N8OOY	Tom & Cheryl Taft	386 Cherry Street	Groveport	OH	43125	614-202-9042

ATCO MEMBERSHIP INFORMATION

Membership in ATCO (Amateur Television in Central Ohio) is open to any licensed radio amateur who has an interest in amateur television. The annual dues are \$10.00 per person payable on January 1 of each year. Additional members within an immediate family and at the same address are included at no extra cost.

ATCO publishes this Newsletter quarterly in January, April, July, and October. It is sent to each member without additional cost. All Newsletters are sent via Email unless the member does not have an internet connection.

The membership period is from January 1ST to December 31ST. New members joining before August will receive all ATCO Newsletters published during the current year prior to the date they join ATCO. For example, a new member joining in June will receive the January and April issues in addition to the July and October issues. For those joining after August 1ST, they can elect to receive a complementary October issue with the membership commencing the following year or get the previous (3) Newsletters. Your support of ATCO is welcomed and encouraged.

Membership expiration notices will be sent out in January in lieu of Newsletters for those with an expired membership.

NOTE: Dues records on your individual portion of the ATCO website are listed as the date money is received and shows due one year from that date. The actual expiration is on January of the following year so we can keep the dues clock consistent with the beginning of each year.

ATCO CLUB OFFICERS

President: Art Towslee WA8RMC	Repeater trustees: Art Towslee WA8RMC
V. President: Ken Morris W8RUT	Ken Morris W8RUT
Treasurer: Bob Tournoux N8NT	Dale Elshoff WB8CJW
Secretary: Frank Amore WA8HFK	Statutory agent: Frank Amore WA8HFK
Corporate trustees: Same as officers	Newsletter editor: Art Towslee WA8RMC

ATCO MEMBERSHIP APPLICATION

RENEWAL NEW MEMBER DATE _____

CALL _____

OK TO PUBLISH PHONE # IN NEWSLETTER YES NO

HOME PHONE _____

NAME _____

INTERNET Email ADDRESS _____

ADDRESS _____

CITY _____ STATE _____ ZIP _____ - _____

FCC LICENSED OPERATORS IN THE IMMEDIATE FAMILY _____

COMMENTS _____

ANNUAL DUES PAYMENT OF \$10.00 ENCLOSED CHECK MONEY ORDER

Make check payable to ATCO or Bob Tournoux & mail to: Bob Tournoux N8NT 3569 Oarlock CT Hilliard, Ohio 43026. Or, if you prefer, pay dues via the Internet with your credit card. Go to www.atco.tv and fill out the "pay ATCO dues" section. Alternately, you can use the ATCO web site www.atco.tv/PayDues.aspx directly. Credit card payment is made through "PayPal" but you DO NOT need to join PayPal to send your dues. Simply DO NOT fill out the password details and there will be no "PayPal" involvement.

ATCO Newsletter
c/o Art Towslee-WA8RMC
180 Fairdale Ave
Westerville, Ohio 43081

FIRST CLASS MAIL

**REMEMBER...CLUB DUES ARE NEEDED.
CHECK THE
MEMBERS PAGE OF ATCO WEBSITE FOR THE EXPIRATION DATE.
SEND N8NT A CHECK OR USE PAYPAL IF EXPIRED.**
